

OPERATION AND PARTS MANUAL

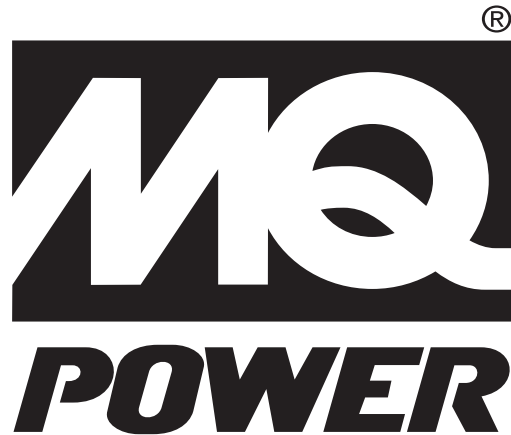

WHISPERWATT™ SERIES MODEL DCA-56SPX 60 Hz GENERATOR

(PARTS LIST NO. B4871301604 S/N 3796699~)

Revision #1 (04/14/10)

**THIS MANUAL MUST ACCOMPANY
THE EQUIPMENT AT ALL TIMES.**



WARNING



CALIFORNIA — Proposition 65 Warning

Diesel engine exhaust and some of its constituents are known to the State of California to cause cancer, birth defects and other reproductive harm.

**MQ POWER DCA-56SPX
WHISPERWATT™ GENERATOR**

California Proposition 65 Warning 2
Here's How To Get Help 3
Table Of Contents 4
Parts Ordering Procedures 5
Specifications 6
Dimensions (Top, Side, Front) 7
Safety Message Alert Symbols 8-9
Rules for Safe Operation 10-15
Generator Decals 16-17
Installation 18-19
General Information 20
Major Components 21
Generator Control Panel 23
Engine Operating Panel 24-25
Output Terminal Panel Familiarization 26-28
Load Application 29
Gauge Reading 30
Pre-Setup 31-34
Generator Start-up Procedure (Manual) 35-36
Generator Start-up Procedure (Auto Mode) 37
Generator Shut-Down Procedure 38
Maintenance (Engine) 39-41
Maintenance (Trailer) 42-45
Trailer Wiring Diagram 46
Generator Wiring Diagram 47
Engine Wiring Diagram 48
Troubleshooting (Engine) 49-50
Troubleshooting (Generator) 51
Engine Controller Troubleshooting 52
Explanation of Code in Remarks Column 54
Suggested Spare Parts 55

COMPONENT DRAWINGS

Generator Assembly 56-57
Control Box Assembly 58-59
Engine and Radiator Assembly 60-65
Output Terminal Assembly 66-67
Actuator Assembly 68-69
Battery Assembly 70-71
Muffler Assembly 72-73
Fuel Tank Assembly 74-75
Enclosure Assembly 76-79
Rubber Seals Assembly 80-81
Nameplate and Decals 82-83

Terms and Condition of Sale — Parts 84

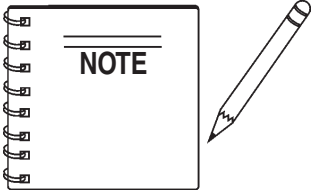

Specification and part number are subject to change without notice.

PARTS ORDERING PROCEDURES

Ordering parts has never been easier! Choose from three easy options:

Effective:
January 1st, 2006

www.mqpower.com



Order via Internet (Dealers Only):

Order parts on-line using Multiquip's SmartEquip website!

- View Parts Diagrams
- Order Parts
- Print Specification Information



If you have an MQ Account, to obtain a Username and Password, E-mail us at: parts@multiquip.com.

To obtain an MQ Account, contact your District Sales Manager for more information.

Goto www.multiquip.com and click on **Order Parts** to log in and save!

Use the **internet** and qualify for a **5% Discount** on *Standard orders* for all orders which include complete part numbers.*

Note: Discounts Are Subject To Change



Order via Fax (Dealers Only):

All customers are welcome to order parts via Fax.

Domestic (US) Customers dial:
1-800-6-PARTS-7 (800-672-7877)

Fax your order in and qualify for a **2% Discount** on *Standard orders* for all orders which include complete part numbers.*

Note: Discounts Are Subject To Change



Order via Phone: Domestic (US) Dealers Call:
1-800-427-1244

Non-Dealer Customers:

Contact your local Multiquip Dealer for parts or call 800-427-1244 for help in locating a dealer near you.



International Customers should contact their local Multiquip Representatives for Parts Ordering information.

When ordering parts, please supply:

- | | |
|---|--|
| <input type="checkbox"/> Dealer Account Number | <input type="checkbox"/> Specify Preferred Method of Shipment: |
| <input type="checkbox"/> Dealer Name and Address | <input checked="" type="checkbox"/> UPS/Fed Ex <input checked="" type="checkbox"/> DHL |
| <input type="checkbox"/> Shipping Address (if different than billing address) | <input type="checkbox"/> Priority One <input checked="" type="checkbox"/> Truck |
| <input type="checkbox"/> Return Fax Number | <input type="checkbox"/> Ground |
| <input type="checkbox"/> Applicable Model Number | <input type="checkbox"/> Next Day |
| <input type="checkbox"/> Quantity, Part Number and Description of Each Part | <input type="checkbox"/> Second/Third Day |

NOTICE

All orders are treated as *Standard Orders* and will ship the same day if received prior to 3PM PST.

WE ACCEPT ALL MAJOR CREDIT CARDS!



DCA-56SPX — SPECIFICATIONS

Table 1. Generator Specifications		
Model	DCA-56SPX	
Type	Revolving field, self ventilated, open protected type synchronous generator	
Armature Connection	Series	
Phase	Single Phase 3-Wire	
Standby Output	58.8 KW (TBD KVA)	
Prime Output	56 KW (TBD KVA)	
Voltage	240V/120	
Frequency	60 Hz	
Speed	1800 rpm	
Power Factor	1.0	
Aux. AC Power	Single Phase, 60 Hz	
Voltage	120 V	
Output	4.8 KW (2.4 KW x 2)	
Table 2. Engine Specifications		
Model	IZUZU FF-4BGIT	
Type	4 Cycle, water-cooled, direct injection, turbocharged	
No. of Cylinders	4 cylinders	
Bore x Stroke	4.13 in. x 4.92 in. (105 mm x 125 mm)	
Rated Output	87 HP/1800 rpm	
Displacement	264.2 cu. in. (4,329 cc)	
Starting	Electric	
Coolant Capacity	3.43 gal. (13.0 liters)	
Lube Oil Capacity	3.49 gal. (13.2 liters)	
Fuel Tank Capacity	39.6 gal. (150 liters)	
Fuel Consumption	4.5 gal. (17.0 L)/hr at full load	3.8 gal. (14.3 L)/hr at 3/4 load
	2.4 gal. (9.0 L)/hr at 1/2 load	1.5 gal. (5.6 L)/hr at 1/4 load
Battery	12V (80Ah) x 1	
Fuel	#2 Diesel Fuel	

DCA-56SPX — DIMENSIONS (TOP, SIDE AND FRONT)

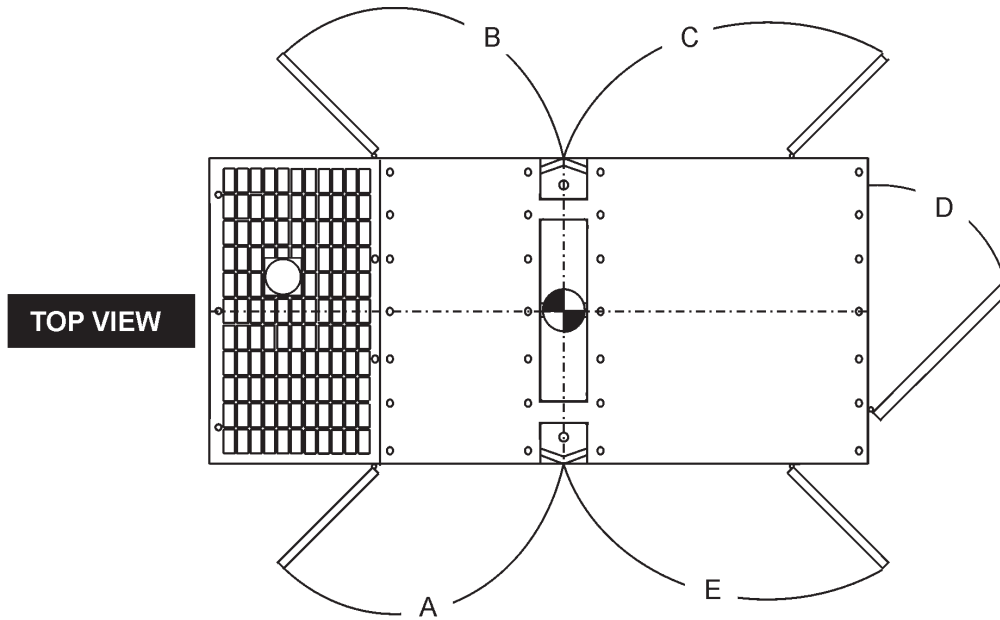

Figure 1. Dimensions

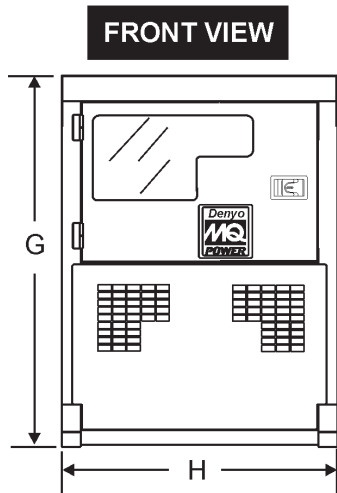
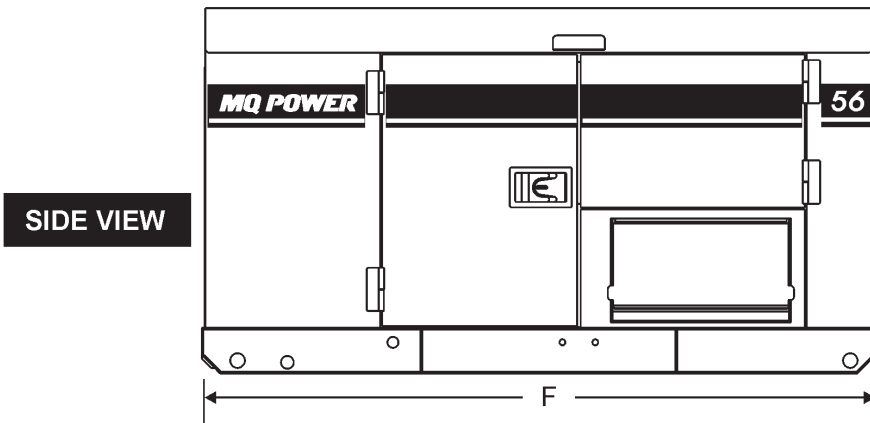
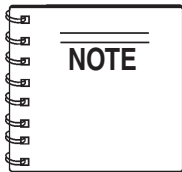

TABLE 3. DIMENSIONS			
Reference Letter	Dimension ft. (mm.)	Reference Letter	Dimension ft. (mm.)
A	35.8 in. (910 mm.)	F	94.49 in. (2,400 mm.)
B	35.8 in. (910 mm.)	G	55.12 in. (1,400 mm.)
C	29.5 in. (750 mm.)	H	35.43 in. (900 mm.)
D	35.8 in. (770 mm.)		
E	29.5 in. (750 mm.)		

DCA-56SPX — SAFETY MESSAGE ALERT SYMBOLS

FOR YOUR SAFETY AND THE SAFETY OF OTHERS!

Safety precautions should be followed at all times when operating this equipment. Failure to read and understand the Safety Messages and Operating Instructions could result in injury to yourself and others.



This Owner's Manual has been developed to provide complete instructions for the safe and efficient operation of the MQ Power **Model DCA-56SPX Whisperwatt™ Generator**.

Before using this generator, ensure that the operating individual has read and understands all instructions in this manual.

SAFETY MESSAGE ALERT SYMBOLS

The three (3) Safety Messages shown below will inform you about potential hazards that could injure you or others. The Safety Messages specifically address the level of exposure to the operator, and are preceded by one of three words: **DANGER**, **WARNING**, or **CAUTION**.

DANGER

You **WILL** be **KILLED** or **SERIOUSLY** injured if you do not follow directions.

WARNING

You **COULD** be **KILLED** or **SERIOUSLY** injured if you do not follow directions.

CAUTION

You **CAN** be injured if you do not follow directions

HAZARD SYMBOLS

Potential hazards associated with the operation of this equipment will be referenced with "**Hazard Symbols**" which appear throughout this manual, and will be referenced in conjunction with Safety "**Message Alert Symbols**".

WARNING - LETHAL EXHAUST GASES



Gasoline engine exhaust gases contain poisonous carbon monoxide. This gas is colorless and odorless, and can cause **DEATH** if inhaled. **NEVER** operate this equipment in a confined area or enclosed structure that does not provide ample free flow air.

WARNING - EXPLOSIVE FUEL

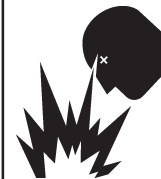

Gasoline is extremely flammable, and its vapors can cause an explosion if ignited. **DO NOT** start the engine near spilled fuel or combustible fluids. **DO NOT** fill the fuel tank while the engine is running or hot.

DO NOT overfill tank, since spilled fuel could ignite if it comes into contact with hot engine parts or sparks from the ignition system. Store fuel in approved containers, in well-ventilated areas and away from sparks and flames. **NEVER** use fuel as a cleaning agent.

WARNING - BURN HAZARDS



Engine components can generate extreme heat. To prevent burns, **DO NOT** touch these areas while the engine is running or immediately after operations. **NEVER** operate the engine with heat shields or heat guards removed.

DANGER - ELECTROCUTION HAZARDS

During operation of this generator, there exists the possibility of **electrocution**, **electrical shock or burn**, which can cause **severe bodily harm** or even **DEATH!**



DCA-56SPX — SAFETY MESSAGE ALERT SYMBOLS

WARNING - ROTATING PARTS



NEVER operate equipment with covers, or guards removed. Keep **fingers, hands, hair** and clothing away from all moving parts to prevent injury.

CAUTION - RESPIRATORY HAZARDS



ALWAYS wear approved **respiratory** protection.

CAUTION - ACCIDENTAL STARTING



ALWAYS place the **engine ON/OFF** switch (**MPEC**) in the **OFF/RESET** position when the generator is not in use.

CAUTION - SIGHT AND HEARING HAZARDS



ALWAYS wear approved **eye** and **hearing** protection.

CAUTION - OVER-SPEED CONDITIONS



NEVER tamper with the factory settings of the engine governor or settings. Personal injury and damage to the engine or equipment can result if operating in speed ranges above maximum allowable.

CAUTION - EQUIPMENT DAMAGE MESSAGES

Other important messages are provided throughout this manual to help prevent damage to your generator, other property, or the surrounding environment.

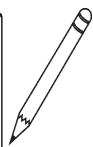
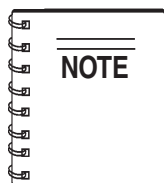

This generator, other property, or the surrounding environment could be damaged if you do not follow instructions.

CAUTION - ENGINE LOAD (WET-STACKING)

Wet-Stacking is a common problem with diesel engines which are operated for extended periods with light or no load applied. When a diesel engine operates without sufficient load (less than 40% of the rated output) it will not operate at its optimum temperature. This will allow unburned fuel to accumulate in the exhaust system, which can foul the fuel injectors, engine valves and exhaust system, including turbochargers, and reduce the operating performance.

In order for a diesel engine to operate at peak efficiency it must be able to provide fuel and air in the proper ratio and at a high enough engine temperature for the engine to completely burn all of the fuel.

Wet stacking does usually cause any permanent damage and can be alleviated if additional load is applied to relieve the condition. It can reduce the system performance and increase maintenance. Applying an increasing load over a period of time until the excess fuel is burned off and the system capacity is reached usually can repair the condition. This can take several hours to burn off the accumulated unburned fuel.

DCA-56SPX — RULES FOR SAFE OPERATION

DANGER - READ THIS MANUAL!

Failure to follow instructions in this manual may lead to **serious injury** or even **DEATH!** This equipment is to be operated by trained and qualified personnel only! This equipment is for industrial use only.

The following safety guidelines should always be used when operating the **DCA-56SPX Whisperwatt™ AC Generator**.

General Safety:

- **DO NOT** operate or service this equipment before reading this entire manual.



The operator **MUST BE** familiar with proper safety precautions and operations techniques before using generator.

- This equipment should not be operated by persons under 18 years of age.
- **NEVER** operate this equipment without proper protective clothing, shatterproof glasses, steel-toed boots and other protective devices required by the job.



- **NEVER** operate this equipment when not feeling well due to fatigue, illness or taking medicine.



- **NEVER** operate this equipment under the influence of drugs or alcohol.



- **ALWAYS** wear proper respiratory (mask), hearing and eye protection equipment when operating the generator.



- Whenever necessary, replace nameplate, operation and safety decals when they become difficult read.

- Manufacturer does not assume responsibility for any accident due to equipment modifications. Unauthorized equipment modification will void all warranties.

- **NEVER** use accessories or attachments, which are not recommended by Multiquip for this equipment. Damage to the equipment and/or injury to user may result.

- **NEVER** touch the hot exhaust manifold, muffler or cylinder. Allow these parts to cool before servicing engine or generators.

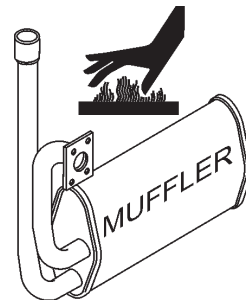

- The engine section of this generators requires an adequate free flow of cooling air. **NEVER** operate the generators in any enclosed or narrow area where free flow of the air is restricted. If the air flow is restricted it will cause serious damage to the generators or engine and may cause injury to people. Remember the generator's engine gives off **DEADLY** carbon monoxide gas.

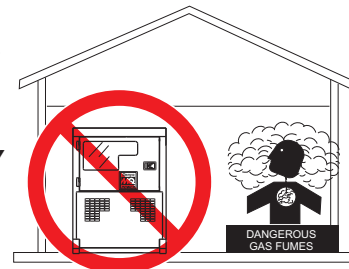

- **ALWAYS** refuel in a well-ventilated area, away from sparks and open flames.

- **ALWAYS** use extreme caution when working with **flammable** liquids. When refueling, **stop the engine** and allow it to cool. **DO NOT smoke** around or near the machine. Fire or explosion could result from fuel vapors, or if fuel is spilled on a hot engine.



- **NEVER** operate the generator in an explosive atmosphere or near combustible materials. An explosion or fire could result causing severe **bodily harm or even death**.



- **NEVER** disconnect any "**emergency or safety devices**". These devices are intended for operator safety. Disconnection of these devices can cause severe injury, bodily harm or even death! Disconnection of any of these devices will void all warranties.

DCA-56SPX — RULES FOR SAFE OPERATION

■ **ALWAYS** be sure the operator is familiar with proper safety precautions and operation techniques before using generators.

NEVER leave the generator unattended, turn off engine when unattended.

Unauthorized equipment modifications will void all warranties.

ALWAYS ensure generator is on level ground before use.

DO NOT place hands or fingers inside generators engine compartment when engine is running.

NEVER run engine without air cleaner. Severe engine damage may occur.

NEVER change or adjust the engine speed which has been set at the factory prior to shipping.

Power Cord Safety

NEVER let power cables or cords *lay in water*.

NEVER *stand in water* while AC power from the generators is being transfer to a load.

NEVER use a defective or frayed power cable. Check the cable for cuts in the insulation.

NEVER use a extension cord that is frayed or damaged where the insulation has been cut.

ALWAYS make certain that proper power or extension cord has been selected for the job See Table 4.

Grounding Safety

ALWAYS make sure that electrical circuits are properly *grounded* per the **National Electrical Code** (NEC) and local codes before operating generator. Severe *injury* or *death!* by electrocution can result from operating an ungrounded generator.

ALWAYS make sure the generators are properly grounded to a suitable earth ground (**GROUND ROD**). See installation in this manual.

NEVER use *gas piping* as an electrical ground.

Maintenance Safety

NEVER lubricate components or attempt service on a running machine.

High Temperatures – Always stop engine and allow the engine to cool before adding fuel, oil or performing service and maintenance functions. Contact with **hot!** components can cause serious burns.



Keep the machinery in proper running condition.

Fix damage to the machine immediately and replace any broken parts immediately.

ALWAYS replace any worn or damaged warning decals.

ALWAYS store equipment properly when it is not being used. Equipment should be stored in a clean, dry location out of the reach of children and un-authorized personnel.

The electrical voltage required to operate the generator can cause severe injury or even death through physical contact with live circuits. Turn all circuit breakers **OFF** before performing maintenance on the generator.

Dispose of hazardous waste properly. Examples of potentially hazardous waste are used motor oil, fuel and fuel filters.

DO NOT use food or plastic containers to dispose of hazardous waste.

DO NOT pour waste, oil or fuel directly onto the ground, down a drain or into any water source.

■ **ALWAYS** allow the machine a proper amount of time to cool before servicing.

■ **ALWAYS** service air cleaner frequently to prevent engine malfunction.

■ **ALWAYS** disconnect the **NEGATIVE battery terminal** before performing service on the generator.

■ Follow all battery safety guidelines listed in this manual when handling or servicing the generator.

WARNING - BURN HAZARDS

To prevent burns, **DO NOT** touch or open any of the below mentioned components while the engine is running or immediately after operations. Always allow sufficient time for the engine and generator to cool before performing maintenance.



■ **Radiator Cap** - Removing the radiator cap while the engine is hot will result in high pressurized, boiling water to gush out of the radiator, causing severe scalding to any persons in the general area of the generator.

■ **Coolant Drain Plug** - Removing the coolant drain plug while the engine is hot will result in hot coolant gushing out of the coolant drain plug, therefore causing severe scalding to any persons in the general area of the generator.



■ **Engine Oil Drain Plug** - Removing the engine oil drain plug while the engine is hot will result in hot oil gushing out of the oil drain plug, therefore causing severe scalding to any persons in the general area of the generator.

Battery Safety

Use the following guidelines when handling the battery:

- The battery contains acids that can cause injury to the eyes and skin. To avoid eye irritation, **always** wear safety glasses.
- Use well insulated gloves when picking up the battery.

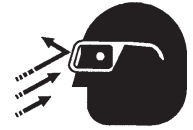

DANGER - EXPLOSION HAZARDS

The risk of an explosion exists when performing service on the battery. To avoid **severe injury** or **DEATH**:

DO NOT drop the battery. There is the possibility of risk that the battery may explode.

DO NOT expose the battery to open flames, sparks, cigarettes etc. The battery contains combustible gases and liquids. If these gases and liquids come in contact with a flame or spark, an explosion could occur.

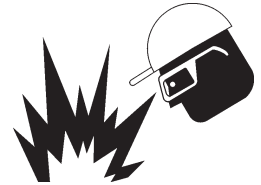

- **ALWAYS** keep the battery charged. If the battery is not charged a buildup of combustible gas will occur.

ALWAYS keep battery charging and cables in good working condition. Repair or replace all worn cables.

ALWAYS recharge the battery in an vented air environment, to avoid risk of a dangerous concentration of combustible gases.

In case the battery liquid (dilute sulfuric acid) comes in contact with **clothing or skin**, rinse skin or clothing immediately with plenty of water.

In case the battery liquid (dilute sulfuric acid) comes in contact with your **EYES**, rinse eyes immediately with plenty of water and contact the nearest doctor or hospital to seek medical attention.

DANGER-Electrocution Hazards

During operation of this generation, there exists the possibility of **electrocution, electrical shock or burn**, which can cause **severe bodily harm** or even **DEATH!**



To avoid these hazards:

NEVER use **damaged** or **worn** cables when connecting equipment to the generator. Make sure power connecting cables are securely connected to the generator's output receptacles, incorrect connections may cause damage to the generators and electrical shock.

NEVER grab or touch a live power cord with wet hands, the possibility exist of electrical shock, electrocution, and even **death!**

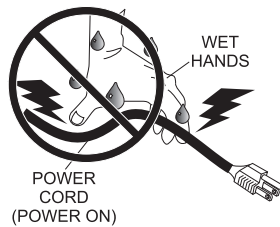

NEVER insert any objects into the output receptacles during operation. This is extremely dangerous. **ALWAYS** turn-off the generators and place all circuit breakers in the "OFF" position when contact with the output receptacles is required. There exist the possibility of **electrocution, electrical shock or burn, which can cause severe bodily harm or even death!**

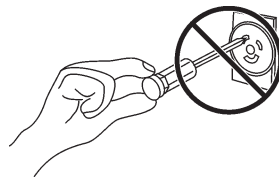

Backfeed to a utility system can cause **electrocution** and or property damage. **NEVER** connect the generators to a building's electrical system without a transfer switch or other approved device. All installations should be performed by a **licensed electrician** in accordance with all applicable laws and electrical codes. Failure to do so could result in electrical shock or burn causing serious injury or even death!

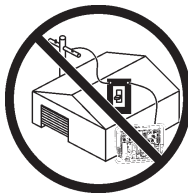

DANGER-Lethal Exhaust Gas Hazards



Engine exhaust gases contain poisonous carbon monoxide. This gas is colorless and odorless, and can cause death if inhaled. **NEVER** operate this equipment in a confined area or enclosed structure that does not provide ample free flow air.



 DANGER

Using a generator indoors **CAN KILL YOU IN MINUTES.**

Generator exhaust contains carbon monoxide. This is a poison you cannot see or smell

		
NEVER use inside a home or garage, even if doors and windows are open		Only use OUTSIDE and far away from windows, doors, and vents.

Avoid other generator hazards.
READ MANUAL BEFORE USE.

Emergencies

ALWAYS know the location of the nearest **fire extinguisher**.



ALWAYS know the location of the nearest **first aid kit**.



In emergencies **always** know the location of the nearest phone or **keep a phone on the job site**. Also know the phone numbers of the nearest **ambulance, doctor** and **fire department**. This information will be invaluable in the case of an emergency.

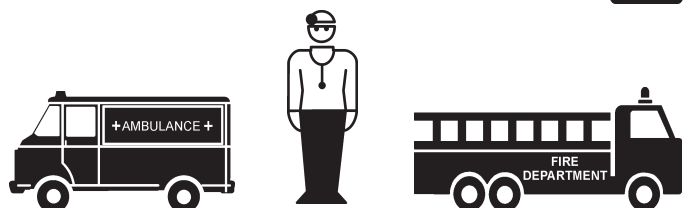



If your generator is trailer mounted, please read the towing and safety requirements listed below.

Towing and Transporting Safety

To reduce the possibility of an accident while transporting the generator on public roads, always make sure the trailer that supports the generator and the towing vehicle are in good operating condition and both units are mechanically sound.

The following list of safety precautions should be followed when towing your generator:

CAUTION - FOLLOW TOWING REGULATIONS

Check with your local county or state safety towing regulations, in addition to meeting **Department of Transportation (DOT) Safety Towing Regulations**, before towing your generator.

- **ALWAYS** shutdown engine before transporting.
- Drain fuel from generator fuel tank before towing.
- If generator is mounted on a trailer, make sure trailer complies with all local and state safety transportation laws. Follow the listed **Towing & Transporting Safety** guidelines for basic towing techniques.
- Make sure the hitch and coupling of the towing vehicle are rated equal to, or greater than the trailer "gross vehicle weight rating."
- **ALWAYS** inspect the hitch and coupling for wear. **NEVER** tow a trailer with defective hitches, couplings, chains etc.
- Check the tire air pressure on both towing vehicle and trailer. **Trailer tires should be inflated to 50 psi cold.** Also check the tire tread wear on both vehicles.
- **ALWAYS** make sure the trailer is equipped with a "Safety Chain".
- **ALWAYS** attach trailer's safety chains to towing vehicle properly.
- **ALWAYS** make sure the vehicle and trailer directional, backup, brake, and trailer lights are connected and working properly.

- DOT Requirements include the following:
 - Connect and test electric brake operation.
 - Secure portable power cables in cable tray with tie wraps.
- The maximum speed for highway towing is **55 MPH** unless posted otherwise. Recommended off-road towing is not to exceed **15 MPH** or less depending on type of terrain.
- Place **chock blocks** underneath wheel to prevent **rolling**, while parked.
- Use the trailer's swivel jack to adjust the trailer height to a level position while parked.
- Avoid sudden stops and starts. This can cause skidding, or jack-knifing. Smooth, gradual starts and stops will improve towing.
- Avoid sharp turns.
- Trailer should be adjusted to a level position at all times when towing.
- Raise and lock trailer wheel stand in up position when transporting.
- The maximum speed for highway towing is **55 MPH** unless posted otherwise. Recommended off-road towing is not to exceed **15 MPH** or less depending on type of terrain.
- Place **support blocks** underneath the trailer's bumper to prevent **tipping**, while parked.
- Avoid sharp turns to prevent rolling.
- **DO NOT** transport generator with fuel in tank.



For more safety tips, see the trailer safety guidelines section in this manual.

DCA-56SPX — GENERATOR DECALS

The DCA-56SPX generator is equipped with a number of safety decals (Figures 2 and 3). These decals are provided for operator safety and maintenance information. The illustration below and on the preceding page show the decals as they appear on the machine. Should any of these decals become unreadable, replacements can be obtained from your dealer.



P/N 6360620104



P/N 6360620204

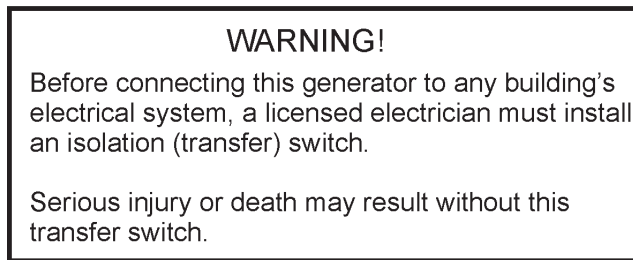

P/N 0820610404

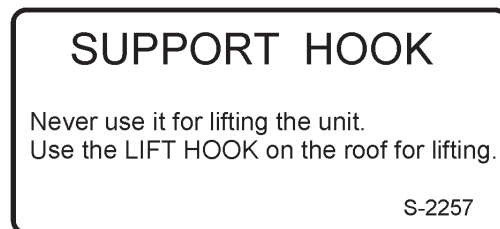

P/N 1320621504

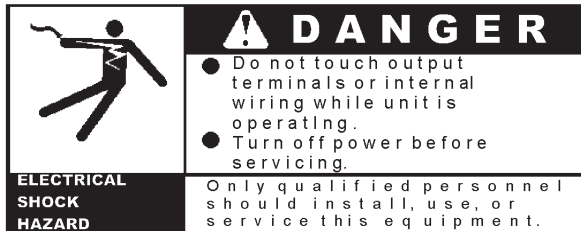

P/N 8700611904

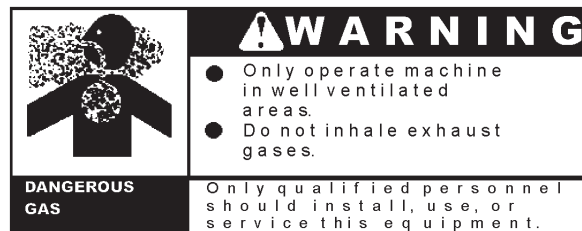

P/N 8700611804

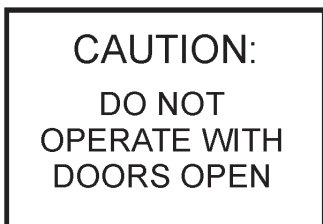

P/N 1630610504

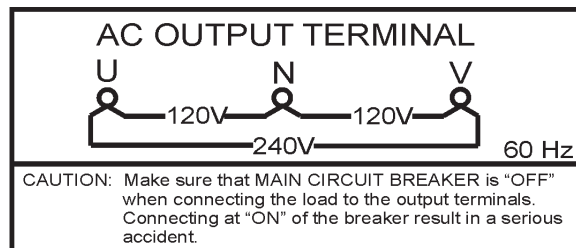

P/N 7670654004

Figure 2. Generator Decals

DCA-56SPX — GENERATOR DECALS



P/N M000001020Q

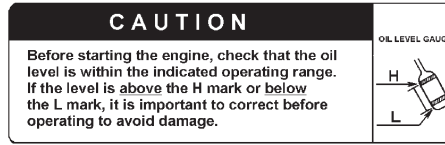

P/N M9503000103



P/N 0800622704



P/N 16306 10304

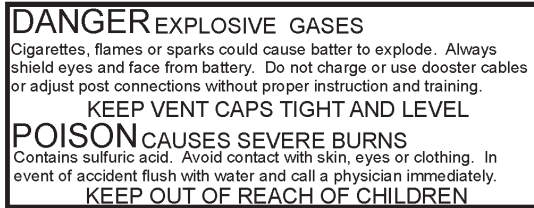

P/N 0820650604



P/N 0800628504



P/N 7670650004



P/N 6360610304



P/N 0800689404



P/N 0800689504

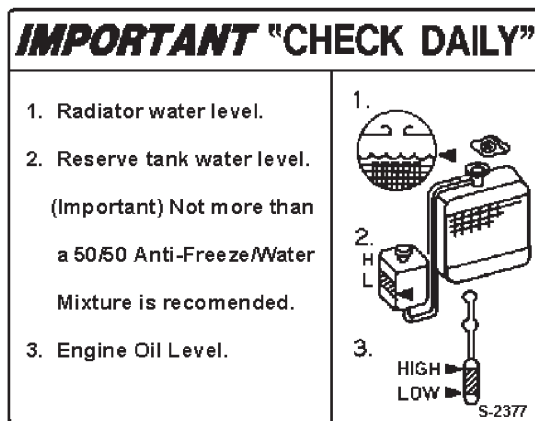

P/N 6390671104



P/N 0840624504



P/N 7670624004

Figure 3. Generator Decals (Cont inued)

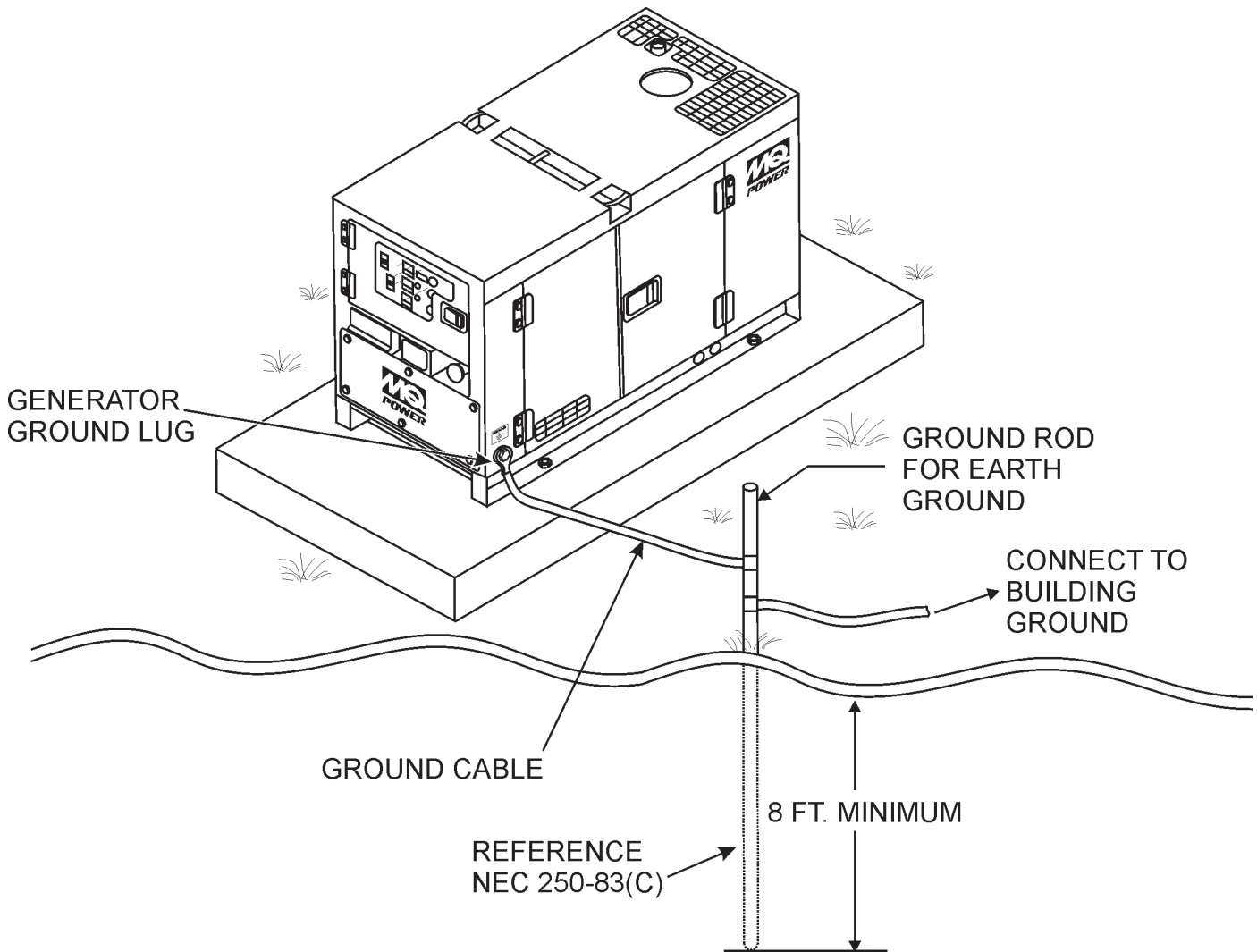

Figure 4. Typical Generator Grounding Application

Outdoor Installation

Install the generator in a area that is free of debris, bystanders, and overhead obstructions. Make sure the generator is on secure level ground so that it cannot slide or shift around. Also install the generator in a manner so that the exhaust will not be discharged in the direction of nearby homes.

The installation site must be relatively free from moisture and dust. All electrical equipment should be protected from excessive moisture. Failure to do will result in deterioration of the insulation and will result in short circuits and grounding.

Foreign materials such as dust, sand, lint and abrasive materials have a tendency to cause excessive wear to engine and alternator parts.

CAUTION - EXHAUST HAZARD

Pay close attention to ventilation when operating the generator inside tunnels and caves. The engine exhaust contains noxious elements. Engine exhaust must be routed to a ventilated area.

Indoor Installation

Exhaust gases from diesel engines are extremely poisonous. Whenever an engine is installed indoors the exhaust fumes must be vented to the outside. The engine should be installed at least two feet from any outside wall. Using an exhaust pipe which is too long or too small can cause excessive back pressure which will cause the engine to heat excessively and possibly burn the valves.

Mounting

The generator must be mounted on a solid foundation (such as concrete) and set firmly on the foundation to isolate vibration of the generator when it is running. The generator must set at least 6 inches above the floor or grade level (in accordance to NFPA 110, Chapter 5-4.1). **DO NOT** remove the metal skids on the bottom of the generator. They are to resist damage to the bottom of the generator and to maintain alignment.

Generator Grounding

To guard against electrical shock and possible damage to the equipment, it is important to provide a good **EARTH** ground.

Article 250 (Grounding) of the National Electrical Code (NEC) provides guide lines for proper grounding and specifies that the cable ground shall be connected to the grounding system of the building as close to the point of cable entry as practical.

NEC articles 250-64(b) and 250-66 set the following grounding requirements:

1. Use one of the following wire types to connect the generator to earth ground.
 - a. Copper - 10 AWG (5.3 mm²) or larger.
 - b. Aluminum - 8 AWG (8.4 mm²) or larger.
2. When grounding the generator (Figure 4) connect the ground cable between the lock washer and the nut on the generator and tighten the nut fully. Connect the other end of the ground cable to earth ground.
3. NEC article 250-52(c) specifies that the earth ground rod should be buried a minimum of 8 ft. into the ground.

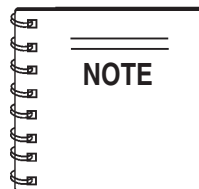

When connecting the generator to any buildings electrical system **ALWAYS** consult with a licensed electrician.

DCA-56SPX Whisperwatt™ Series Familiarization

Generator

The MQ Power Model DCA-56SPX is a 56 kW **generator** (Figure 5) that is designed as a high quality portable (requires a trailer for transport) power source for telecom sites, lighting facilities, power tools, submersible pumps and other industrial and construction machinery.

Engine Operating Panel

The "Engine Operating Panel" is provided with the following:

- Tachometer
- Water Temperature Gauge
- Oil Pressure Gauge
- Charging Ammeter Gauge
- Fuel Level Gauge
- Panel Light/Panel Light Switch
- Pre-Heat Button
- Pre-Heat Lamp
- Auto ON/OFF Engine Controller (MPEC)

Generator Control Panel

The "Generator Control Panel" is provided with the following:

- Frequency Meter (Hz)
- AC Ammeter (Amps)
- AC Voltmeter (Volts)
- Ammeter Change-Over Switch
- Voltage Regulator
- 3-Pole, 250 amp Main Circuit Breaker
- "Control Box" (located behind the Gen. Control Panel)
 - Automatic Voltage Regulator
 - Current Transformer
 - Over-Current Relay
 - Voltage Rectifier
 - Starter Relay
 - Engine Controller (Computer Controlled)
 - Voltage Selector Switch

Output Terminal Panel

The "Output Terminal Panel" is provided with the following:

- Three 120/240V output receptacles (CS-6369), 50A
- Three auxilliary circuit breakers, (for CS-6369), 50A
- Two 120V output receptacles (GFCI), 20A
- Two GFCI circuit breakers, 20A
- Four output terminal lugs (1Ø power)
- Battery Charger (Optional)
- Water Heater (Optional)

Open Delta Excitation System

The DCA-56SPX generator is equipped with the state of the art "**Open-Delta**" excitation system. The open delta system consist of an electrically independent winding wound among stationary windings of the AC output section.

There are four connections of the open delta A, B, C and D. During steady state loads, the power from the voltage regulator is supplied from the parallel connections of A to B, A to D, and C to D. These three phases of the voltage input to the voltage regulator are then rectified and are the excitation current for the exciter section.

When a heavy load, such as a motor starting or a short circuit occurs, the automatic voltage regulator (AVR) switches the configuration of the open delta to the series connection of B to C. This has the effect of adding the voltages of each phase to provide higher excitation to the exciter section and thus better voltage response during the application of heavy loads.

The connections of the AVR to the AC output windings are for sensing only. No power is required from these windings.

The open-delta design provides virtually unlimited excitation current, offering maximum motor starting capabilities. The excitation does not have a "**fixed ceiling**" and responds according the demands of the required load.

Engine

The **DCA-56SPX** is powered by a 4 cylinder, water cooled, direct injection turbocharged, **Isuzu Model FF-4BGIT diesel engine**. This engine is designed to meet every performance requirement for the generator. Reference Table 1 for engine specifications.

In keeping with MQ Power's policy of constantly improving its products, the specifications quoted herein are subject to change without prior notice.

Electric Governor System

The electric governor system controls the RPMs of the engine. When the engine demand increases or decreases, the governor system regulates the frequency variation to $\pm 0.25\%$.

Extension Cables

When electric power is to be provided to various tools or loads at some distance from the generator, extension cords are normally used. Cables should be sized to allow for distance in length and amperage so that the voltage drop between the generator and point of use (load) is held to a minimum. Use the cable selection chart (Table 6) as a guide for selecting proper extension cable size.

DCA-56SPX — MAJOR COMPONENTS

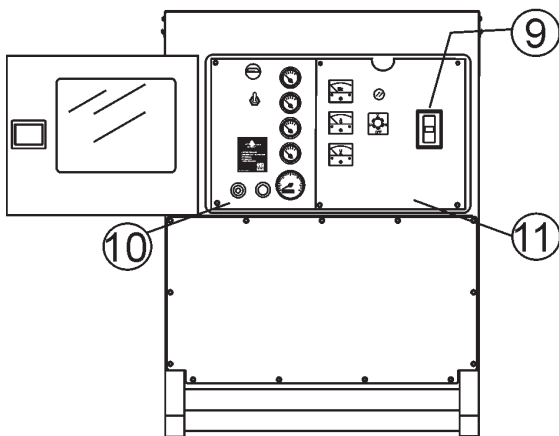
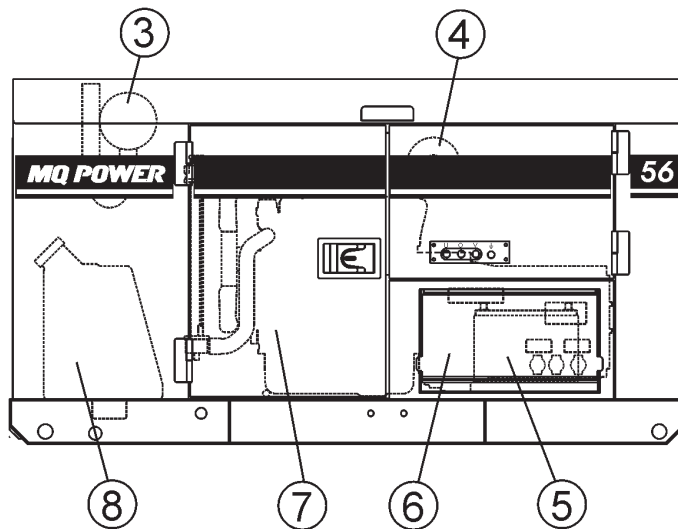
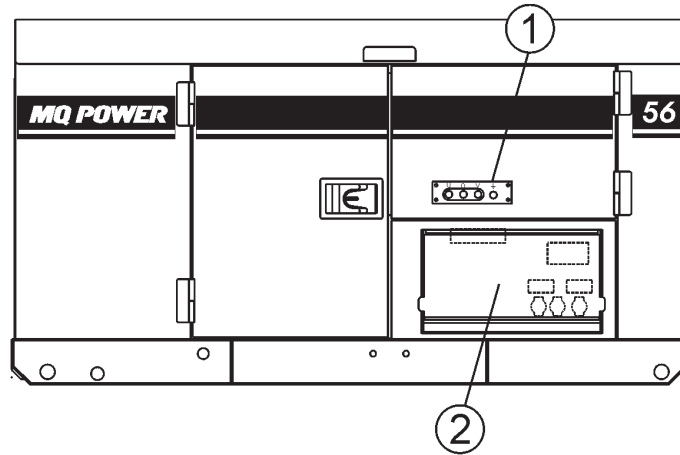

Figure 5. Major Components

Table 4. Generator Major Components	
ITEM NO.	DESCRIPTION
1	Output Terminal Assembly
2	Output Receptacles Assembly
3	Muffler Assembly
4	Air Filter Assembly
5	Battery Assembly
6	Generator Assembly
7	Engine Assembly
8	Fuel Tank Assembly
9	Circuit Breaker Assembly
10	Engine Control Panel Assembly
11	Generator Control Panel Assembly

DCA-56SPX — GENERATOR CONTROL PANEL

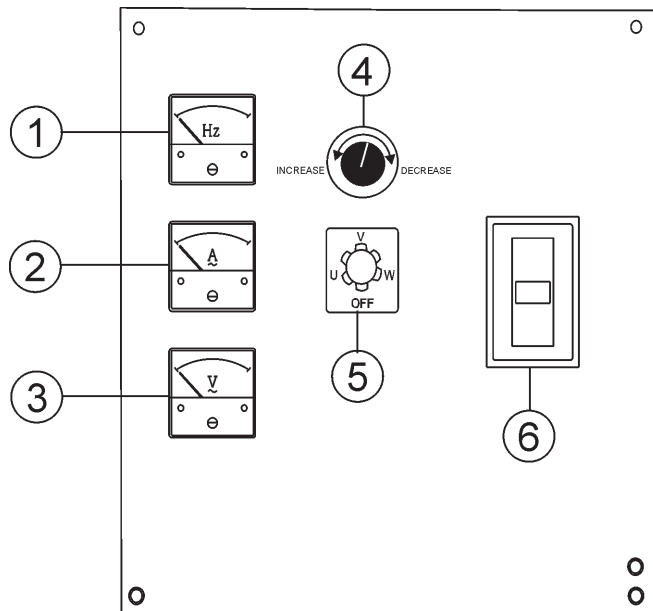

Figure 6. Generator Control Panel

The definitions below describe the controls and functions of the DCA-56SPX **Generator Control Panel** (Figure 6).

1. **Frequency Meter** – Indicates the output frequency in hertz (Hz). Normally 60 Hz.
2. **AC Ammeter** – Indicates the amount of current the load is drawing from the generator per leg selected by the ammeter phase-selector switch.
3. **AC Voltmeter** – Indicates the output voltage present at the **U, O, and V Output Terminal Lugs**.
4. **Voltage Regulator Control** – Allows $\pm 15\%$ manual adjustment of the generator's output voltage.
5. **Ammeter Change-Over Switch** – This switch allows the AC ammeter to indicate the current flowing to the load connected to any phase of the output terminals, or to be switched off. This switch does not effect the generator output in any fashion, it is for current reading only.
6. **Main Circuit Breaker** – This three-pole, 250A main breaker is provided to protect the the **U, O, and V Output Terminal Lugs** from overload.

Located behind the generator control panel is the **Generator Control Box**. This box contains some of the necessary electronic components required to make the generator function.

The **Control Box** is equipped with the following major components:

- Over-Current Relay
- Voltage Rectifier (AVR)
- Starter Relay
- Current Transformer
- Voltage Selector Switch
- Single Phase Circuit Breaker

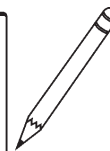
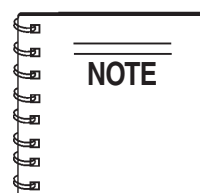

Remember the **overcurrent relay** monitors the current flowing from the **U, O and V Output Terminal Lugs** to the load.

In the event of a short circuit or over current condition, it will automatically trip the 250 amp main breaker.

To restore power to the **Output Terminal Panel**, press the **reset** button on the overcurrent relay and place the **main** circuit breaker in the **closed** position (**ON**).

DCA-56SPX — ENGINE OPERATING PANEL

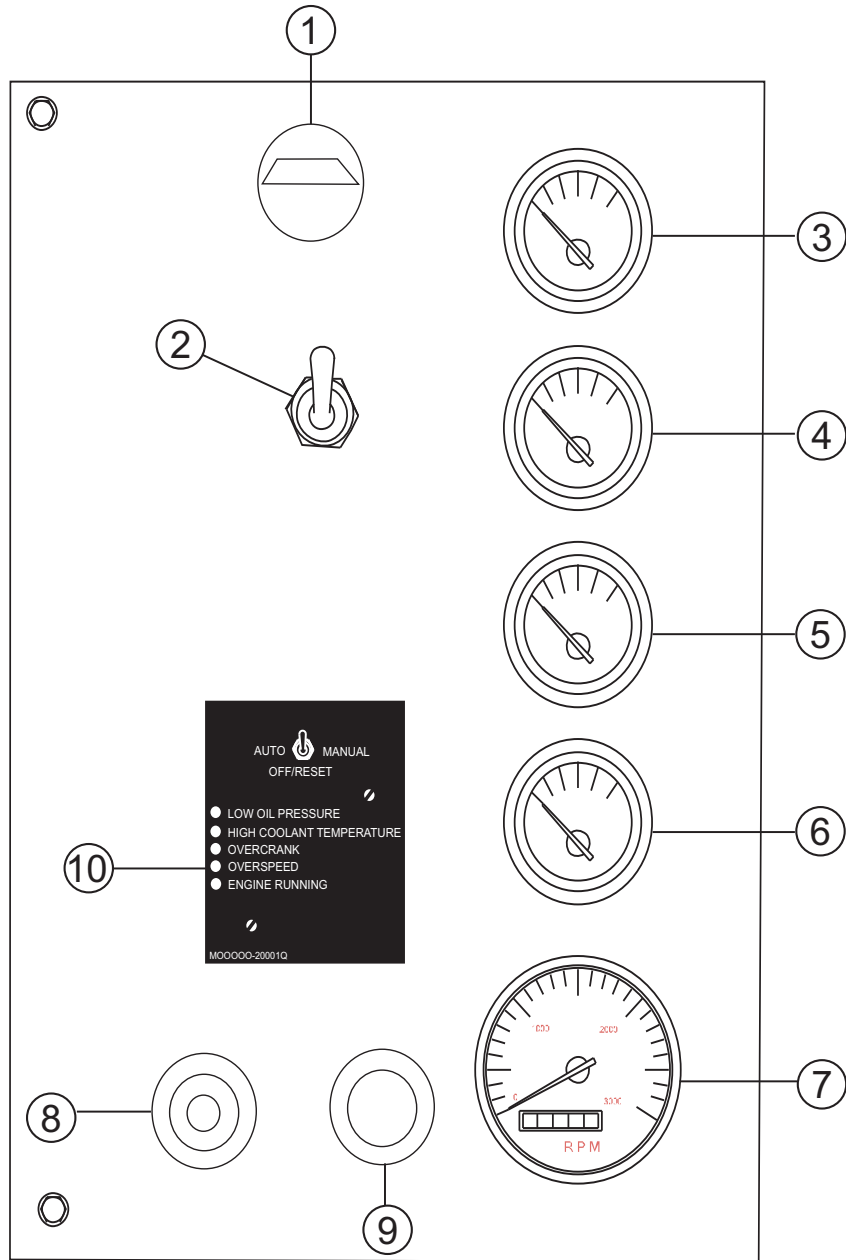

Figure 7. Engine Operating Panel

DCA-56SPX — ENGINE OPERATING PANEL

The definitions below describe the controls and functions of the DCA-56SPX **Engine Operating Panel** (Figure 7).

1. **Panel Light** – Normally used in dark areas or at night time. When activated, panel lights will illuminate. When the generator is not in use be sure to turn the panel light switch to the **OFF** position.
2. **Panel Light Switch** – When activated will turn on control panel light.
3. **Oil Pressure Gauge** – During normal operation this gauge should read between 35 to 65 psi. (241~448 kPa). When starting the generator the oil pressure may read a little higher, but after the engine warms up the oil pressure should return to the correct pressure range.
4. **Water Temperature Gauge** – During normal operation this gauge should read between 180° and 221°F (82° ~105°C)
5. **Charging Ammeter Gauge** – Indicates the current being supplied by the engine's alternator which provides current for generator's control circuits and battery charging system.
6. **Fuel Gauge** - Indicates amount of diesel fuel available.
7. **Tachometer** – Indicates engine speed in RPM's for 60 Hz operation. This meter should indicate 1800 RPM's when the rated load is applied. In addition a built in hour meter will record the number of operational hours that the generator has been in use.
8. **Pre-Heat Lamp** – When ECU is placed in AUTO position pre-heat lamp will be ON. When pre-heating cycle is completed, lamp will turn OFF.
9. **Pre-Heat Button** – Press this button when starting the engine in cold weather conditions. Once the engine glow plugs have warmed, the engine will start automatically.
10. **Auto On/Off Engine Controller (MPEC)** – This controller has a vertical row of status LED's (inset), that when lit, indicate that an engine malfunction (fault) has been detected. When a fault has been detected the engine controller will evaluate the fault and all major faults will shutdown the generator. During **cranking cycle**, The MPEC will attempt to crank the engine for 10 seconds before disengaging.



If the engine does not engage (start) by the third attempt, the engine will be shutdown by the engine controller's **Over Crank Protection** mode. If the engine engages at a speed (RPM's) that is not safe, the controller will shutdown the engine by initializing the **Over Speed Protection** mode.

Also the engine controller will shut down the engine in the event of low oil pressure, high coolant temperature, low coolant level, and loss of magnetic pickup. These conditions can be observed by monitoring the **LED** status indicators on the front of the controller module.

A. MPEC Control Switch – This switch controls the running of the unit. If this switch is set to the **OFF/RESET** position, the unit will not run. When this switch is set to the **MANUAL** position, the generator will start immediately.

If the generator is to be connected to a building's AC power source via an automatic transfer switch (isolation), place the switch in the **AUTO** position. In this position, should an outage occur, the automatic transfer switch (ATS) will start the generator automatically via the generator's auto-start contacts connected to the ATS's start contacts. Please refer to your ATS installation manual for further instructions for the correct installation of the auto-start contacts of the generator to the ATS.

B. Low Oil Pressure – Indicates the engine pressure has fallen below 14 psi (97 kPa). The oil pressure is detected using variable resistive values from the oil pressure sending unit. This is considered a **major** fault.

C. High Coolant Temperature – Indicates the engine temperature has exceeded 221°F. (105°C). The engine temperature is detected using variable resistive values from the temperature sending unit. This is considered a **major** fault.

D. Overcrank Shutdown – Indicates the unit has attempted to start a pre-programmed number of times, and has failed to start. The number of cycles and duration are programmable. It is pre-set at 3 cycles with a 10 second duration. This is considered a **major** fault.

E. Overspeed Shutdown – Indicates the engine is running at an unsafe speed. This is considered a **major** fault.

F. Engine Running – Indicates that engine is running at a safe operating speed.

DCA-56SPX — OUTPUT TERMINAL PANEL FAMILIARIZATION

Output Terminal Panel

The **Output Terminal Panel** (Figure 8) shown below is located on the right-hand side (left from control panel) of the generator. Lift up on the cover to gain access to receptacles and terminal lugs.

Output Terminal Familiarization

The “**Output Terminal Panel**” (Figure 8) is provided with the following:

- Three 120/240V output receptacles (CS-6369), 50A
- Three auxilliary circuit breakers, (for CS-6369), 50A
- Two 120V GFCI receptacles @ 20 amp
- Two GFCI circuit breakers @ 20 amps
- Four Output Terminal Lugs (U, O, V and Ground)

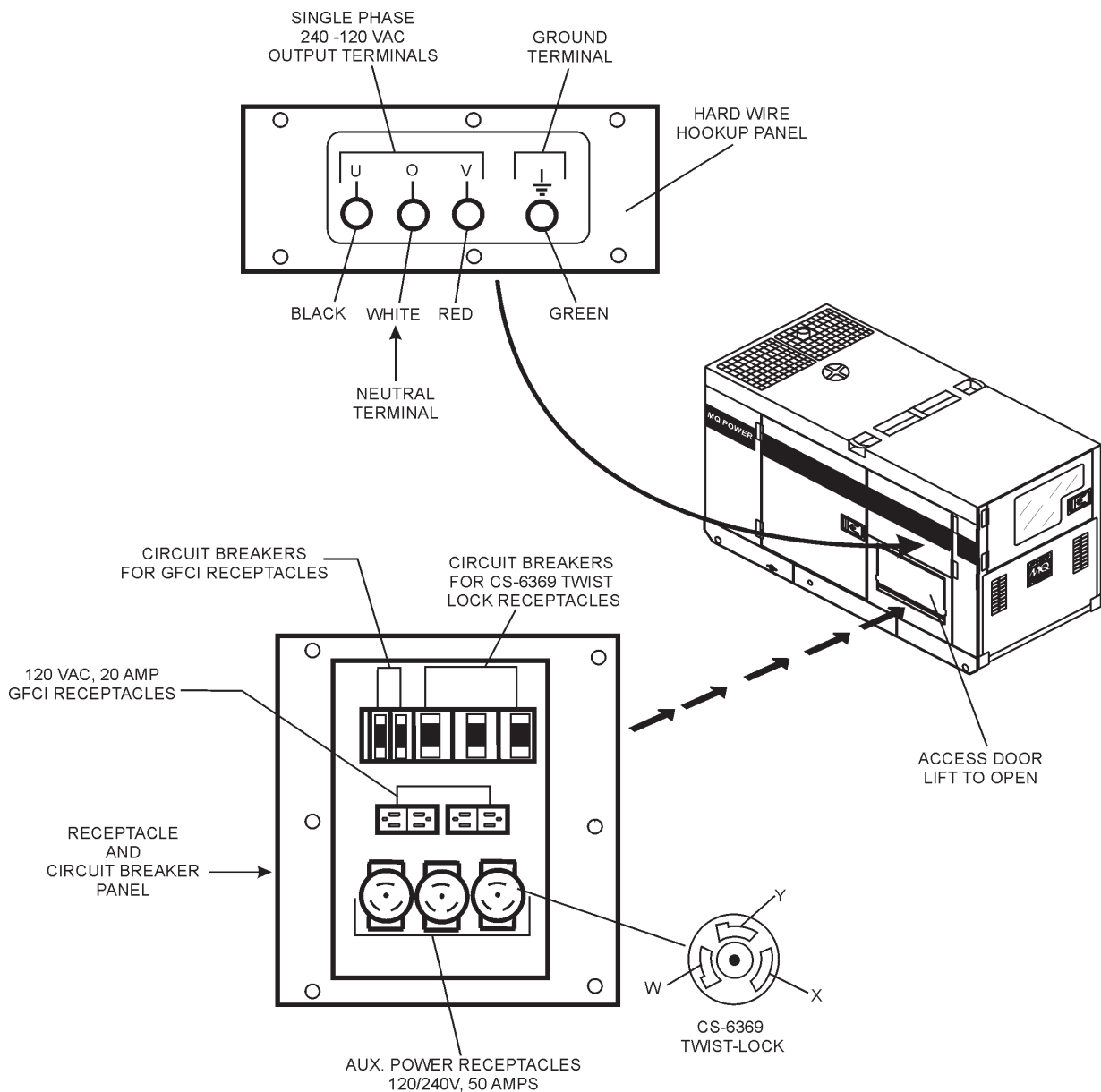

Figure 8. Output Terminal Panel

DCA-56SPX — OUTPUT TERMINAL PANEL FAMILIARIZATION

100 VAC GFCI Receptacles

There are two 120 VAC, 20 amp GFCI (Duplex Nema 5-20R) receptacles provided on the output terminal panel. These receptacles can be accessed in **any voltage selector switch** position. Each receptacle is protected by a 20 amp circuit breaker. These breakers are located directly above the GFCI receptacles. Remember the load output (current) of both GFCI receptacles is dependent on the load requirements of the U, O, and V output terminal lugs.

Pressing the **reset** button resets the GFCI receptacle after being tripped. Pressing the **Test Button** (See Figure 9) in the center of the receptacle will check the GFCI function. Both receptacles should be tested at least once a month.

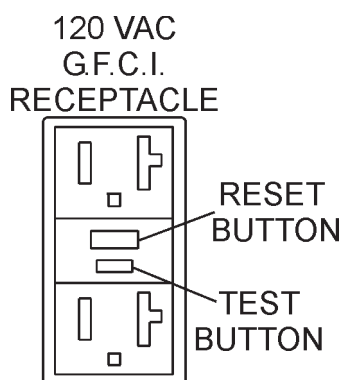

Figure 9. G.F.C.I. Receptacle

Twist Lock Dual Voltage 120/240 VAC Receptacles

There are three 120/240V, 50 amp auxilliary twist-lock (CS-6369) receptacles (Figure 10) provided on the output terminal panel. These receptacles can **only** be accessed when the voltage selector switch is placed in the **single-phase 240/120 position**.

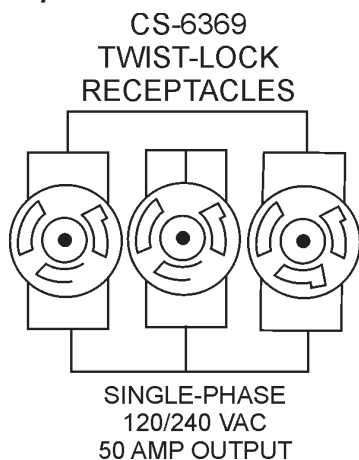

Figure 10. 120/240V Twist-Lock Auxiliary Receptacles

Each auxilliary receptacle is protected by a 50 amp circuit breaker. These breakers are located directly above the GFCI receptacles. Remember the load output (current) on all three receptacles is dependent on the load requirements of the **Output Terminal Lugs**.

Turn the **voltage regulator control knob** (Figure 11) on the control panel to obtain the desired voltage. Turning the knob clockwise will **increase** the voltage, turning the knob counter-clockwise will **decrease** the voltage.



Figure 11. Voltage Regulator Control Knob

Removing the Plastic Face Plate (Hard Wire Hookup Panel)

The **Output Terminal Lugs** are protected by a plastic face plate cover (Figure 12). Un-screw the securing bolts and lift the plastic terminal cover to gain access to the terminal enclosure.

After the load wires have been securely attached to the terminal lugs, reinstall the plastic face plate.

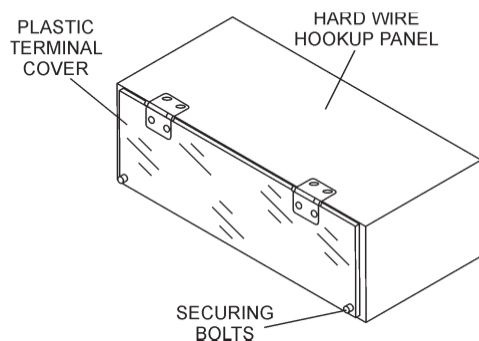

Figure 12. Plastic Face Plate (Output Terminal Lugs)

DCA-56SPX — OUTPUT TERMINAL PANEL FAMILIARIZATION

Connecting Loads

Loads can be connected to the generator by the **Output Terminal Lugs** or the convenience receptacles (Figure 13). Make sure to read the operation manual before attempting to connect a load to the generator.

To protect the output terminals from overload, a 3-pole, 250A **main** circuit breaker is provided. Make sure to switch **ALL** circuit breakers to the **OFF** position prior to starting the engine.

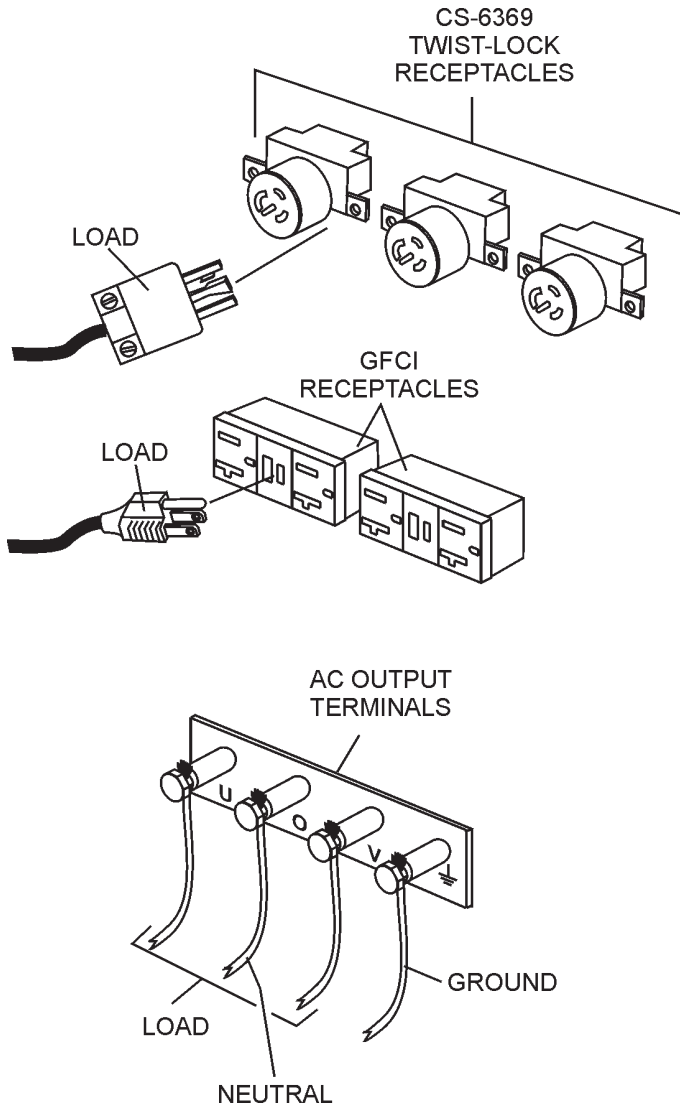

Figure 13. Connecting Loads

Over Current Relay

An **over current relay** (Figure 14) is connected to the main circuit breaker. In the event of an overload, both the circuit breaker and the over current relay may trip. If the circuit breaker can not be reset, the **reset button** on the over current relay must be pressed. The over current relay is located in the control box.

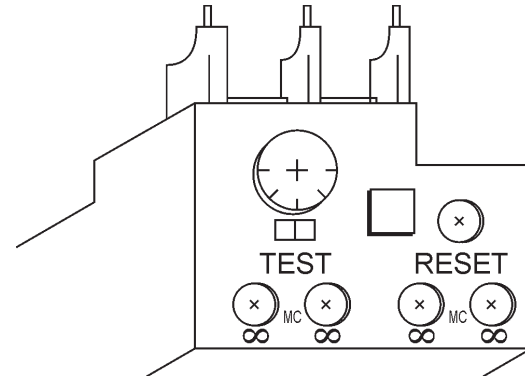

Figure 14. Over Current Relay

DCA-56SPX — LOAD APPLICATION/MAXIMUM AMPERAGE

Single Phase Load

Always be sure to check the nameplate on the generator and equipment to insure the wattage, amperage, frequency, and voltage requirements are satisfactorily supplied by the generator for operating the equipment.

Generally, the wattage listed on the nameplate of the equipment is its rated output. Equipment may require 130—150% more wattage than the rating on the nameplate, as the wattage is influenced by the efficiency, power factor and starting system of the equipment.

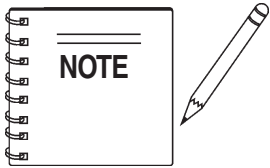

If wattage is not given on the equipment's name plate, approximate wattage may be determined by multiplying nameplate voltage by the nameplate amperage.

$$\text{WATTS} = \text{VOLTAGE} \times \text{AMPERAGE}$$

The power factor of this generator is 0.8. See Table 5 below when connecting loads.

Type Of Load	Power Factor
Single-phase induction motors	0.4 - 0.75
Electric heaters, incandescent lamps	1.0
Fluorescent lamps, mercury lamps	0.4 - 0.9
Electronic devices, communication equipment	1.0
Common power tools	0.8

Current in Amperes	Load In Watts		Maximum Allowable Cable Length			
	At 100 Volts	At 200 Volts	#10 Wire	#12 Wire	#14 Wire	#16 Wire
2.5	300	600	1000 ft.	600 ft.	375 ft.	250 ft.
5	600	1200	500 ft.	300 ft.	200 ft.	125 ft.
7.5	900	1800	350 ft.	200 ft.	125 ft.	100 ft.
10	1200	2400	250 ft.	150 ft.	100 ft.	
15	1800	3600	150 ft.	100 ft.	65 ft.	
20	2400	4800	125 ft.	75 ft.	50 ft.	

CAUTION: Equipment damage can result from low voltage.

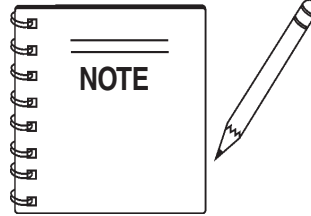

Motors and motor-driven equipment draw much greater current for starting than during operation.

An inadequate size connecting cable which cannot carry the required load can cause a voltage drop which can burn out the appliance or tool and overheat the cable. See Table 6.

- When connecting a resistance load such as an incandescent lamp or electric heater, a capacity of up to the generating set's rated output (kW) can be used.
- When connecting a fluorescent or mercury lamp, a capacity of up to the generating set's rated output (kW) multiplied by 0.6 can be used.
- When connecting an electric drill or other power tools, pay close attention to the required starting current capacity.

When connecting ordinary power tools, a capacity of up to the generating set's rated output (kW) multiplied by 0.8 can be used.

⚠ DANGER - ELECTRICAL SYSTEM HAZARDS

Before connecting this generator to any building's electrical system, a **licensed electrician** must install an **isolation (transfer) switch**. Serious damage to the building's electrical system may occur without this transfer switch.

Generator Amperage

Table 7 describes the generator's current output capability.

Rated Voltage	Maximum Amps
Single Phase 120 Volt	233 X 2 amps
Single Phase 240 Volt	233 amps

DCA-56SPX — GAUGE READING/TERMINAL PANEL CONNECTIONS

How to Read the Output Terminal Gauges.

The gauges on the control panel are provided to help observe how much power is being supplied at the **Output terminal lugs**.

Reading Amperage

To determine the amperage at a terminal lug, set the **AC Ammeter Change-Over Switch** to the appropriate setting (Figure 15) to activate the **AC Ammeter Gauge** (Figure 16) and read the available amperage at the terminal lug.

For example, to measure the amperage at the U terminal lug, set the **AC Ammeter Change-Over Switch** to U and read the **AC Ammeter Gauge**.

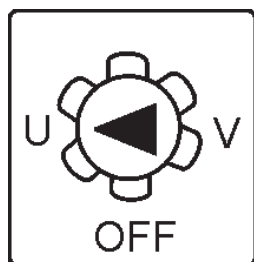

Figure 15. AC Ammeter Change-Over Switch

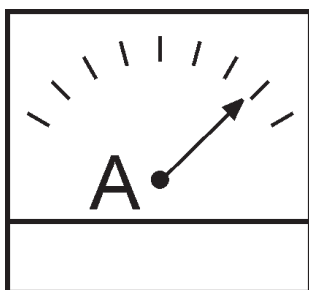
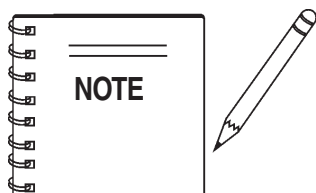

Figure 16. AC Ammeter (Amp reading on U lug)



The **ammeter** gauge will only show a reading when the **Output Terminal Lugs** are connected to a load and in use.

UOV Terminal Output Voltages

240/120V output voltages can be obtained using the **Output Terminal Lugs**.

The voltage regulator (VR) allows the user to increase or decrease the selected voltage.

1Ø 240 Output Terminal Lug Voltages

1. Connect the load wires to the **Output Terminal Lugs** as shown in (Figure 17)

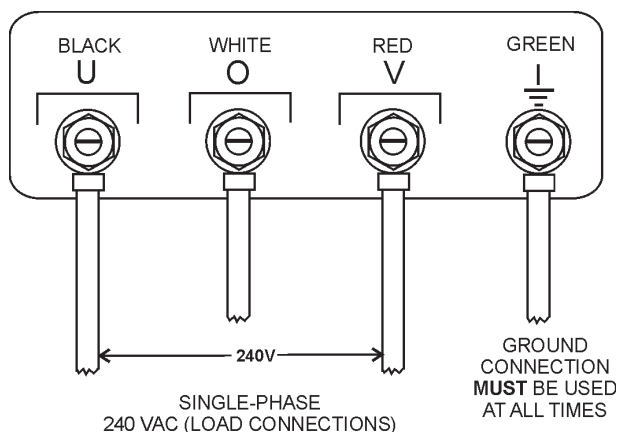

Figure 17. Output Terminal Lugs 240 Single Phase Connections

2. Turn the voltage regulator knob (Figure 18) clockwise to increase voltage output, turn counterclockwise to decrease voltage output.



Figure 18. Voltage Regulator Knob (139V/240V)

1Ø 120 Output Terminal Lug Voltages

1. Connect the load wires to the **Output Terminal Lugs** as shown in (Figure 19)

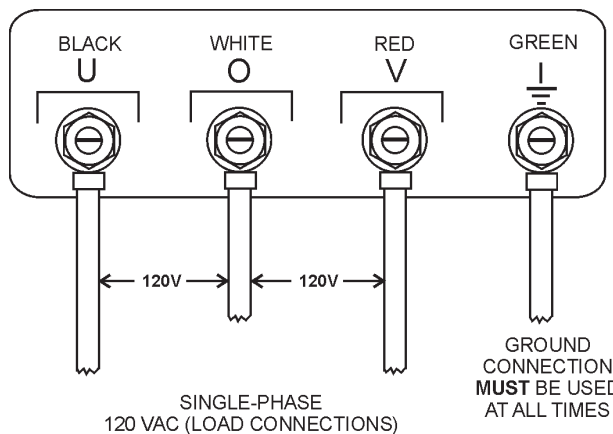

Figure 19. Output Terminal Lugs 120 Single Phase Connections

2. Turn the voltage regulator knob (Figure 18) clockwise to increase voltage output, turn counterclockwise to decrease voltage output.

Circuit Breakers

To protect the generator from an overload, a 3-pole, 90 amp, **main** circuit breaker is provided to protect the **U,O, and V Output Terminals** from overload. In addition two single-pole, 20 amp **GFCI** circuit breakers are provided to protect the GFCI receptacles from overload. Two 50 amp **load** circuit breakers have also been provided to protect the auxiliary receptacles from overload. Make sure to switch **ALL** circuit breakers to the **OFF** position prior to starting the engine.

Lubrication Oil

Fill the engine crankcase with lubricating oil through the filler hole, but **DO NOT** overfill. Make sure the generator is level and verify that the oil level is maintained between the two notches (Figure 20) on the dipstick. See Table 8 for proper selection of engine oil.

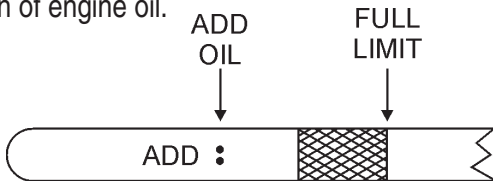

Figure 20. Engine Oil Dipstick

When checking the engine oil, be sure to check if the oil is clean. If the oil is not clean, drain the oil by removing the oil drain plug, and refill with the specified amount of oil as outlined in the **Isuzu Engine Owner's Manual**. Oil should be warm before draining.

Other types of motor oils may be substituted if they meet the following requirements:

- API Service Classification CC/SC
- API Service Classification CC/SD
- API Service Classification CC/SE
- API Service Classification CC/SF

°F		°C		OIL: SAE	
122	50			10W/40	
104	40			30	
86	30			10W/40	
68	20			15W/30	
50	10			10W/30	
32	0			10W	
-14	-10			5W/30	
-4	-20			ARCTIC OIL	
-22	-30				
-40	-40				

Fuel Check

! DANGER - EXPLOSION/FIRE HAZARDS

Fuel spillage on a **hot** engine can cause a **fire** or **explosion**. If fuel spillage occurs, wipe up the spilled fuel completely to prevent fire hazards. **NEVER** smoke around or near the generator.



Refilling the Fuel System

! CAUTION - REFUELING THE GENERATOR

ONLY properly trained personnel who have read and understand this section should refill the fuel tank system.

This generator has an internal fuel tank located inside the trailer frame and may also be equipped with an optional environmental fuel tank (Figure 21). **ALWAYS** fill the fuel tanks with clean fresh **#2 diesel fuel**. **DO NOT** fill the fuel tanks beyond their capacities.

Pay attention to the fuel tank capacity when replenishing fuel. The fuel tank cap must be closed tightly after filling. Handle fuel in a safety container. If the container does not have a spout, use a funnel. Wipe up any spilled fuel immediately.

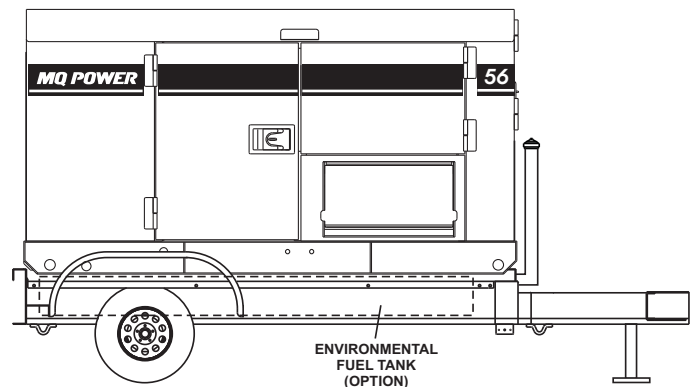

Figure 21. Internal Fuel Tank System

Refueling Procedure:

! WARNING - RESPIRATORY HAZARDS

Diesel fuel and its vapors are dangerous to your health and the surrounding environment. Avoid skin contact and/or inhaling fumes.



1. **Level Tanks** – Make sure fuel cells are level with the ground. Failure to do so will cause fuel to spill from the tank before reaching full capacity (Figure 22).

! CAUTION - REFUELING THE GENERATOR

ALWAYS place trailer on firm level ground before refueling to prevent spilling and maximize the amount of fuel that can be pumped into the tank.

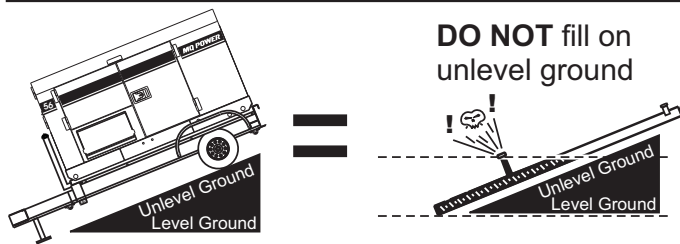
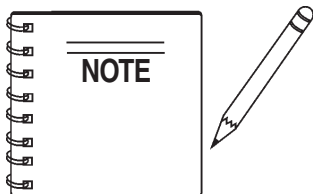

Figure 22. Only Fill on Level Ground



ONLY! use **#2 diesel fuel** when refueling.

2. Remove fuel cap (internal fuel tank) and fill fuel tank as shown Figure 23.

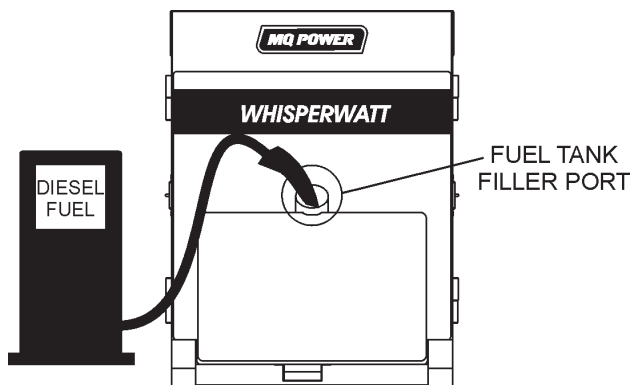
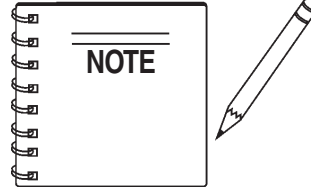

Figure 23. Fueling the Generator



If generator is equipped with an environmental fuel tank, reference Figures 24 and 25.

3. **NEVER overfill fuel tank** – It is important to read the fuel gauge when filling trailer fuel tank. **DO NOT** wait for fuel to rise in filler neck (Figure 24).

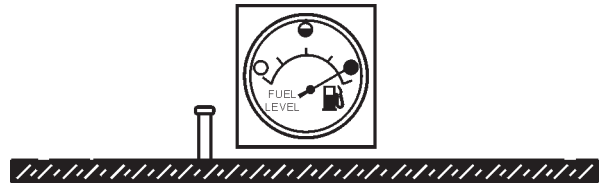

Figure 24. Full Fuel Tank

! CAUTION - REFUELING THE GENERATOR

DO NOT OVER-FILL fuel system. Leave room for fuel expansion. Fuel expands when heated (Figure 25).



Figure 25. Fuel Expansion

Coolant (Antifreeze/Summer Coolant/Water)

ISUZU recommends antifreeze/summer coolant for use in their engines, which can be purchased in concentrate (and mixed with 50% demineralized water) or pre-diluted. See the **ISUZU Engine Owner's Manual** for further details.

! WARNING - BURN HAZARDS

If adding coolant/antifreeze mix to the radiator, **DO NOT** remove the radiator cap until the unit has completely cooled. The possibility of **hot!** coolant exists which can cause severe burns.



Day-to-day addition of coolant is done from the recovery tank. When adding coolant to the radiator, **DO NOT** remove the radiator cap until the unit has completely cooled. See Table 9 for engine, radiator, and recovery tank coolant capacities. Make sure the coolant level in the recovery tank is always between the "H" and the "L" markings.

Table 9. Coolant Capacity

Engine and Radiator	3.43 Gal. (13 liters)
Reserve Tank	2 Quarts (1.9 liters)

Operation Freezing Weather

When operating in freezing weather, be certain the proper amount of antifreeze (Table 10) has been added.

Table 10. Anti-Freeze Operating Temperatures

Vol % Anti-Freeze	Freezing Point	
	°C	°F
50	-37	-34

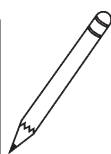
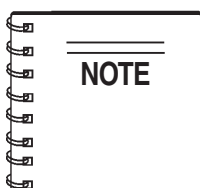

When the antifreeze is mixed with water, the antifreeze mixing ratio **must be** less than 50%.

Cleaning the Radiator

The engine may overheat if the radiator fins become overloaded with dust or debris. Periodically clean the radiator fins with compressed air. Cleaning inside the machine is dangerous, so clean only with the engine turned off and the **negative** battery terminal disconnected.

Air Cleaner

Periodic cleaning/replacement is necessary. Inspect it in accordance with the **ISUZU Engine Owner's Manual**.

Fan Belt Tension

A slack fan belt may contribute to overheating, or to insufficient charging of the battery. Inspect the fan belt for damage and wear and adjust it in accordance with the **ISUZU Engine Owner's Manual**.

The fan belt tension is proper if the fan belt bends 10 to 15 mm (Figure 26) when depressed with the thumb as shown below.

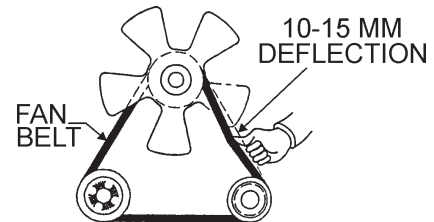
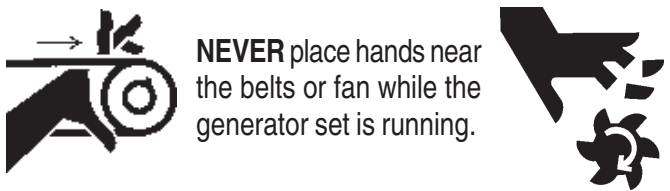

Figure 26. Fan Belt Tension

! CAUTION - ROTATING PARTS

NEVER place hands near the belts or fan while the generator set is running.



Battery

This unit is of negative ground **DO NOT** connect in reverse. Always maintain battery fluid level between the specified marks. Battery life will be shortened, if the fluid level are not properly maintained. Add only distilled water when replenishment is necessary.

DO NOT over fill. Check to see whether the battery cables are loose. Poor contact may result in poor starting or malfunctions. **Always** keep the terminals firmly tightened. Coating the terminals with an approved battery terminal treatment compound. Replace battery with only recommended type battery. The battery type used in this generator is BCI Group 27.

The battery is sufficiently charged if the specific gravity of the battery fluid is 1.28 (at 68° F). If the specific gravity should fall to 1.245 or lower, it indicates that the battery is dead and needs to be recharged or replaced.

Before charging the battery with an external electric source, be sure to disconnect the battery cables.

Battery Cable Installation

ALWAYS be sure the battery cables (Figure 27) are properly connected to the battery terminals as shown below. The **Red Cable** is connected to the positive terminal of the battery, and the **Black Cable** is connected to the negative terminal of the battery.

! CAUTION - BATTERY SERVICING SAFETY

ALWAYS disconnect the negative terminal **FIRST** and reconnect negative terminal **LAST**.

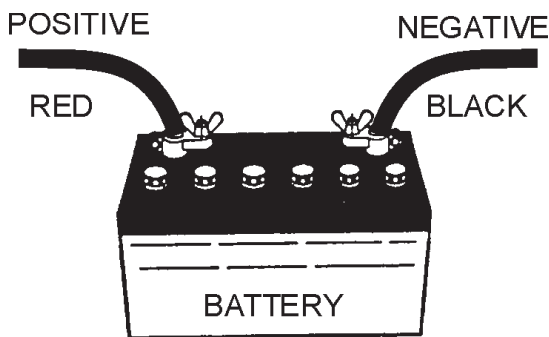
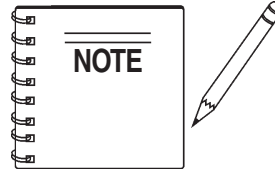

Figure 27. Battery Connections

When connecting battery do the following:

1. **NEVER** connect the battery cables to the battery terminals when the **MPEC Control Switch** is in either the **MANUAL** position. **ALWAYS** make sure that the **MPEC Control Switch** is in the **OFF/RESET** position when connecting the battery.
2. Place a small amount of battery terminal treatment compound around both battery terminals. This will ensure a good connection and will help prevent corrosion around the battery terminals.



If the battery cable is connected incorrectly, electrical damage to the generator will occur. Pay close attention to the polarity of the battery when connecting the battery.

! CAUTION - BATTERY SERVICING SAFETY

Inadequate battery connections may cause poor starting of the generator, and create other malfunctions.

Alternator

The polarity of the alternator is negative grounding type. When an inverted circuit connection takes place, the circuit will be in short circuit instantaneously resulting the alternator failure.

DO NOT put water directly on the alternator. Entry of water into the alternator can cause corrosion and damage the alternator.

Wiring

Inspect the entire generator for bad or worn electrical wiring or connections. If any wiring or connections are exposed (insulation missing) replace wiring immediately.

Piping and Hose Connection

Inspect all piping, oil hose, and fuel hose connections for wear and tightness. Tighten all hose clamps and check hoses for leaks.

If any hose (**fuel** or **oil**) lines are defective replace them immediately.

DCA-56SPX — GENERATOR START-UP PROCEDURE (MANUAL)

Before Starting

⚠ CAUTION - LETHAL EXHAUST HAZARD

The engine's exhaust contains harmful emissions. **ALWAYS have adequate ventilation when operating.** Direct exhaust away from nearby personnel.

⚠ WARNING - STARTING THE GENERATOR

NEVER! manually start the engine with the **main, GFCI** or **auxiliary** circuit breakers in the **ON** (closed) position.

1. Place the **main, G.F.C.I.,** and **aux.** circuit breakers (Figure 28) in the **OFF** position prior to starting the engine.

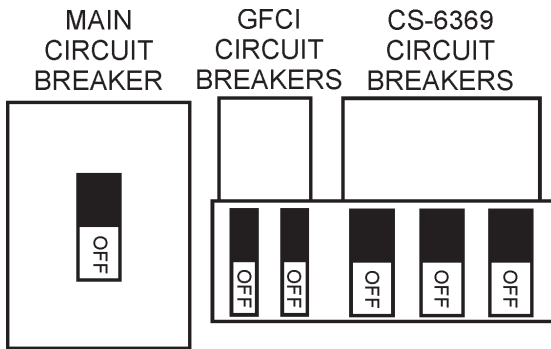

Figure 28. Main, Aux. and GFCI Circuit Breakers (OFF)

3. Connect the load to the **receptacles** or the **output terminal lugs** as shown in Figures 8 and 13. These load connection points can be found on the output terminal panel and the output terminal panel's hard wire hookup panel.
4. The output terminal lugs are protected by a plastic cover. Remove this cover to gain access to the terminals. Tighten terminal nuts securely to prevent load wires from slipping out.
5. Close all engine enclosure doors (Figure 29).

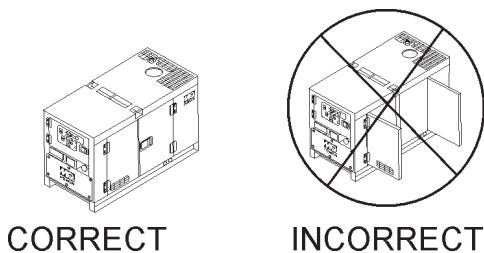

Figure 29. Engine Enclosure Doors

Manual Start-up Procedure

1. Place the **MPEC Control Switch** in the **MANUAL** position to start the engine (Figure 30).

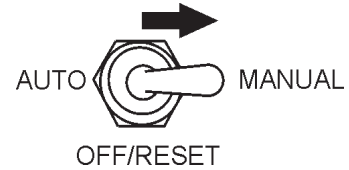

Figure 30. MPEC Control Switch (Manual Position)

2. Once the engine starts, let it engine run for 1-2 minutes. Listen for any abnormal noises. If any abnormalities exists shutdown the engine and correct the problem.

3. Verify that the **Engine Running** status LED on the MPEC unit (Figure 31) is **ON** (lit) after the engine has been started.



Figure 31. Engine Running LED (ON)

4. The generator's frequency meter (Figure 32) should be displaying the 60 cycle output frequency in **HERTZ**.

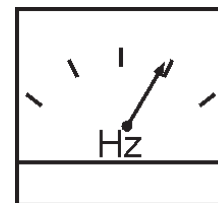

Figure 32. Frequency Meter (Hz)

DCA-56SPX — GENERATOR START-UP PROCEDURE (MANUAL)

6. The generator's AC-voltmeter (Figure 33) will display the generator's output in **VOLTS**. If the voltage is not within the specified tolerance, use the voltage adjustment control knob (Figure 34) to increase or decrease the desired voltage.

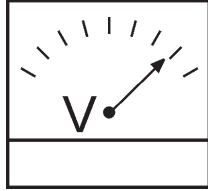

Figure 33. Voltmeter



Figure 34. Voltage Adjust Control Knob

7. The ammeter (Figure 35) will indicate **zero amps** with no load applied. When a load is applied, the ammeter will indicate the amount of current that the load is drawing from the generator.

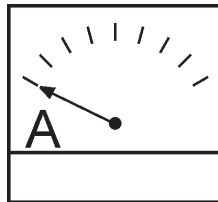

Figure 35. Ammeter (No Load)

8. The engine oil pressure gauge (Figure 36) will indicate the oil pressure of the engine. Under normal operating conditions the oil pressure is approximately 35 to 65 psi. (241~448 kPa). When starting the generator.

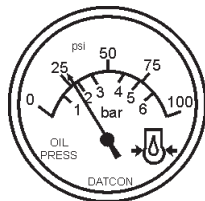

Figure 36. Oil Pressure Gauge

9. The **coolant temperature gauge** (Figure 37) will indicate the coolant temperature. Under normal operating conditions the coolant temperature should be between 180~221 °F (82~105 °C), **Green Zone**.

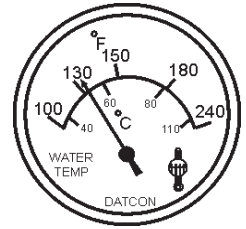

Figure 37. Coolant Temperature Gauge

10. The **tachometer gauge** (Figure 38) will indicate the speed of the engine when the generator is operating. Under normal operating conditions this speed is approximately 1800 RPM's.

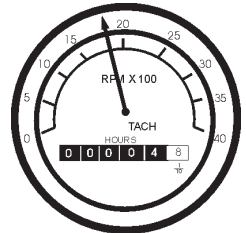

Figure 38. Engine Tachometer Gauge

11. Place the **main**, **GFCI**, and **aux.** circuit breakers in the **ON** position (Figure 39).

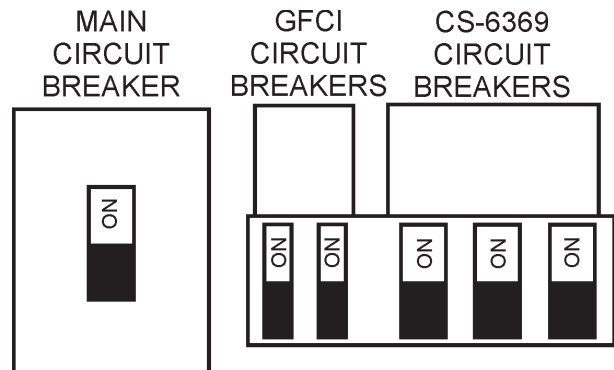

Figure 39. Main, Aux. and GFCI Circuit Breakers (ON)

12. Observe the generator's ammeter (Figure 40) and verify it reads the anticipated amount of current with respect to the load. The ammeter will only display a current reading if a load is in use.

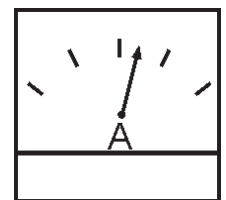

Figure 40. Ammeter (Load)

13. The generator will run until manually stopped or an abnormal condition occurs.

DCA-56SPX — GENERATOR START-UP PROCEDURE (AUTO MODE)

Starting (Auto Mode)

DANGER - ELECTRICAL SYSTEM HAZARDS

Before connecting this generator to any building's electrical system, a **licensed electrician** must install an **isolation (transfer) switch**. Serious damage to the building's electrical system may occur without this transfer switch.



CAUTION - BACKUP GENERATOR USE

When connecting the generator to a isolation (transfer) switch, **ALWAYS** have power applied to the generator's internal battery charger. This will ensure that the engine will not fail due to a dead battery.

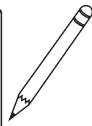
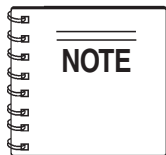

When the generator is set in the **AUTO** mode, the generator will **automatically start** in the event of commercial power falling below a prescribed level by means of a contact closure that is generated automatically by a transfer switch.

WARNING - AUTO MODE MAINTENANCE

When running the generator in the **AUTO** mode, remember the generator can start up at any time without warning. **NEVER** attempt to perform any maintenance when the generator is in the auto mode.

When starting generator in **AUTO** mode use the "**Manual Start-up**" procedure except where noted (see below).

1. Perform steps 1 through 5 in the **Before Starting** section.
2. Place the **MPEC Control Switch** (Figure 41) in the **AUTO** position



Figure 41. MPEC Control Switch (AUTO)

3. Continue operating the generator as outlined in the **Manual Start-up Procedure** (start at step 5).

WARNING - SHUTTING DOWN THE GENERATOR

NEVER stop the engine suddenly except in an emergency.

Normal Shutdown Procedure

To shutdown the generator use the following procedure:

1. Place both the **MAIN**, **GFCI** and **LOAD** circuit breakers as shown in Figure 39 to the **OFF** position.
2. Let the engine cool by running it at low speed for 3-5 minutes with no load applied.
3. Place the **MPEC Control Switch** (Figure 42) to the **OFF/RESET** position.



Figure 42. MPEC Control Switch (Off/Reset)

4. Verify that the **all** status LED on the MPEC display are **OFF** (not lit).
5. Remove all loads from the generator.
6. Inspect entire generator for any damage or loosening of components that may have occurred during operation.

Emergency Shutdown Procedure

1. Place the **MPEC Control Switch** switch (Figure 42) to the **OFF/RESET** position.
2. To shut-down the engine in the event of an emergency, switch the **MAIN**, **GFCI** and **LOAD** (Figure 39) circuit breakers to **OFF** position.

TABLE 11. INSPECTION/MAINTENANCE		10 Hrs DAILY	250 Hrs	500 Hrs	1000 Hrs
ENGINE	Check Engine Fluid Levels	X			
	Check Air Cleaner	X			
	Check Battery Acid Level	X			
	Check Fan Belt Condition	X			
	Check for Leaks	X			
	Check for Loosening of Parts	X			
	Replace Engine Oil and Filter * 1		X		
	Clean Air Filter		X		
	Check Fuel Filter/Water Separator Bowl	X			
	Clean Unit, Inside and Outside		X		
	Change Fuel Filter			X	
	Clean Radiator and Check Coolant Protection Level*2			X	
	Replace Air Filter Element * 3			X	
	Check all Hoses and Clamps * 4				X
	Clean Inside of Fuel Tank				X
GENERATOR	Measure Insulation Resistance Over 3M ohms		X		
	Check Rotor Rear Support Bearing			X	

*1 Replace engine oil and filter at 100 hours, first time only.

*2 Add "Supplemental Coolant Additives (SCA'S)" to recharge the engine coolant.

*3 Replace primary air filter element when restriction indicator shows a vacuum of 625 mm (25 in. H₂O).

*4 If blowby hose needs to be replaced, ensure that the slope of the blowby hose is at least a 1/2 inch per foot, with no sags or dips that could collect moisture and/or oil.

General Inspection

Prior to each use, the generator should be cleaned and inspected for deficiencies. Check for loose, missing or damaged nuts, bolts or other fasteners. Also check for fuel, oil, and coolant leaks. Use Table 11 as a general maintenance guideline **Engine Side** (Refer to the Engine Instruction Manual)

Air Cleaner

Every 250 hours: Remove air cleaner element and clean the heavy duty paper element with light spray of compressed air. Replace the air cleaner as needed.

Air Cleaner with Dust Indicator

This indicator is attached to the air cleaner. When the air cleaner element is clogged, air intake restriction becomes greater and the dust indicator signal shows **RED** meaning the element needs changing or service. After changing the air element, press the dust indicator button to reset the indicator.

Service Daily

If the engine is operating in very **dusty** or **dry grass** conditions, a clogged air cleaner will result. This can lead to a loss of power, excessive carbon buildup in the combustion chamber and high fuel consumption. Change air cleaner more **frequently** if these conditions exist.

Fuel Addition

Add diesel fuel (the grade may vary according to season and locations).

Removing Water from the Fuel Tank

After prolonged use, water and other impurities accumulate in the bottom of the tank. Occasionally inspect the fuel tank for water contamination and drain the contents if required.

During cold weather, the more empty volume inside the tank, the easier it is for water to condense. This can be reduced by keeping the tank full with diesel fuel.

Air Removal

If air enters the fuel injection system of a diesel engine, starting becomes impossible. After running out of fuel, or after disassembling the fuel system, bleed the system according to the following procedure. See the *VOLVO Engine Manual* for details.

To restart after running out of fuel, turn the switch to the “ON” position for 15-30 seconds. Try again, if needed. This unit is equipped with an automatic air bleeding system.

Check Oil Level

Check the crankcase oil level prior to each use, or when the fuel tank is filled. Insufficient oil may cause severe damage to the engine. Make sure the generator is level. The oil level must be between the two notches on the dipstick as shown in Figure 31.

Replacing Oil Filter

- Remove the old oil filter.
- Apply a film of oil to the gasket on the new oil filter.
- Install the new oil filter.
- After the oil cartridge has been replaced, the engine oil will drop slightly. Run the engine for a while and check for leaks before adding more oil if needed. Clean excessive oil from engine.

Cleaning the Fuel Strainer

Clean the fuel strainer if it contains dust or water. Remove dust or water in the strainer cap and wash it in gasoline. Securely fasten the fuel strainer cap so that fuel will not leak. Check the fuel strainer every 200 hours of operation or once a month.

Replacing Fuel Filter

- Replace the fuel filter cartridge with new one every 500 hours or so.
- Loosen the drain plug at the lower top of the fuel filter. Drain the fuel in the fuel body together with the mixed water. **DO NOT** spill the fuel during disassembly.
- Vent any air.

Flushing Out Radiator and Replacing Coolant

- Open both cocks located at the crankcase side and at the lower part of the radiator and drain coolant. Open the radiator cap while draining. Remove the overflow tank and drain.
- Check hoses for softening and kinks. Check clamps for signs of leakage.
- Flush the radiator by running clean tap water through radiator until signs of rust and dirt are removed. **DO NOT** clean radiator core with any objects, such as a screwdriver.
- Tighten both cocks and replace the overflow tank.
- Replace with coolant as recommended by the engine manufacturer.
- Close radiator cap tightly.

WARNING - BURN HAZARDS

Allow engine to **cool** when flushing out radiator. Flushing the radiator while hot could cause serious burns from water or steam.



Generator Storage

For long term storage of the generator the following is recommended:

- Fill the fuel tank completely. Treat with a fuel stabilizer if necessary.
- Completely drain the oil from the crankcase and refill if necessary with fresh oil.
- Clean the entire generator, internal and external.
- Cover the generating set and store in a clean, dry place.
- Disconnect the battery.
- Make sure engine coolant is at proper level.
- If generator is mounted on a trailer, jack trailer up and place on blocks so tires do not touch the ground or block and completely remove the tires.

Jacket Water Heater and Internal Battery Charger 120 VAC Input Receptacles (OPTIONAL)

This generator can be optionally equipped with two 120 VAC, 20 amp input receptacles located on the output terminal panel.

The purpose of these receptacles is to provide power via commercial power to the *jacket water heater* and *internal battery charger*.

These receptacles will **ONLY** function when commercial power has been supplied to them (Figure 43). To apply commercial power to these receptacles, a power cord of adequate size will be required (See Table 6).

When using the generator in *hot* climates there is no reason to apply power to jacket water heater. However, if the generator will be used in *cold* climates it is always a good idea to apply power to the jacket water heater at all times. To apply power to the jacket water heater simply apply power to the jacket water heater receptacle via commercial power using an power cord of adequate size.

If the generator will be used daily, the battery should normally not require charging. If the generator will be idle (not used) for long periods of time, apply power to the battery charger receptacle via commercial power using an power cord of adequate size.

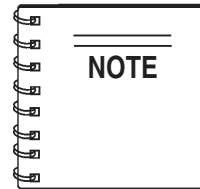

To ensure adequate starting capability, **always** have power applied to the generator's *internal battery charger*.

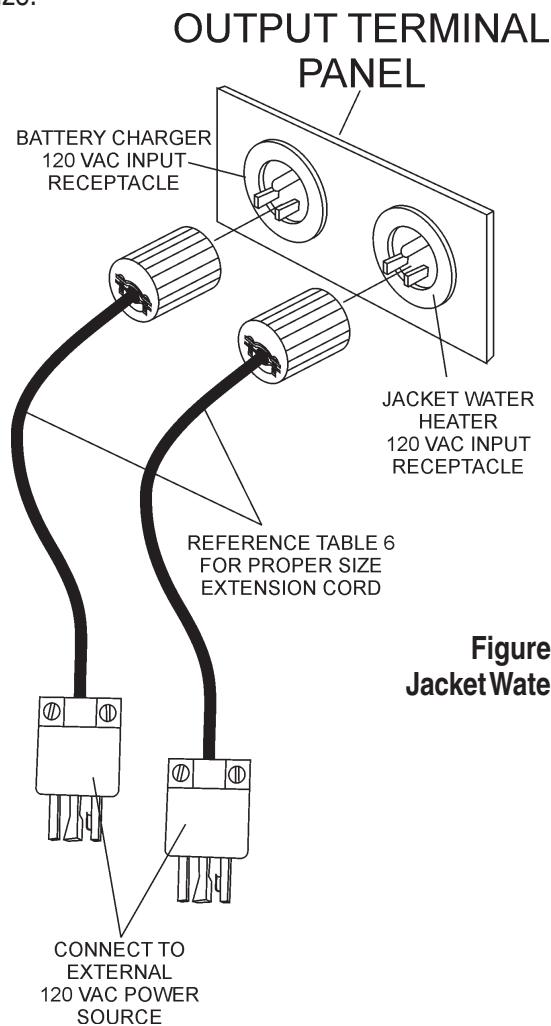

Figure 43. Battery Charger & Jacket Water Heater Power Connections

Trailer Maintenance

This section is intended to provide the user with generic trailer service and maintenance information. The service and maintenance guidelines referenced in this section refer to a wide range of trailers.

Remember periodic inspection of the trailer will ensure safe towing of the generator and will prevent personal injury and damage to the equipment.

The definitions below describe some of the major components of a typical trailer that would be used with the DCA-56SPX *Whisperwatt™* Generator.

1. **Fuel Cell** - Provides an adequate amount of fuel for the equipment in use. Fuel cells must be empty when transporting equipment.
2. **Braking System** - System employed in stopping the trailer. Typical braking systems are electric, surge, hydraulic, hydraulic-surge and air.
3. **GVWR**- Gross Vehicle Weight Rating (GVWR) is the maximum number of pounds the trailer can carry, including the fuel cell (empty).
4. **Frame Length** - Measurement is from the ball hitch to the rear bumper (reflector).
5. **Frame Width** - Measurement is from fender to fender
6. **Jack Stand** - Trailer support device with maximum pound requirement from the tongue of the trailer.
7. **Coupler** - Type of hitch used on the trailer for towing.
8. **Tire Size** - Indicates the diameter of the tire in inches (10,12,14, etc.), and the width in millimeters (175,185,205, etc.). The tire diameter must match the diameter of the tire rim.
9. **Tire Ply** - The tire ply (layers) number is rated in letters; 2-ply,4-ply,6-ply, etc.
10. **Wheel Hub** - The wheel hub is connected to the trailer's axle.
11. **Tire Rim** - Tires mounted on a tire rim. The tire rim must match the size of the tire.
12. **Lug Nuts** - Used to secure the wheel to the wheel hub. Always use a torque wrench to tighten down the lug nuts. See Table 16 and Figure 59 for lug nut tightening and sequence.
13. **Axle** - Indicates the maximum weight the axle can support in pounds, and the diameter of the axle expressed in inches. Please note that some trailers have a double axle. This will be shown as 2-6000 lbs., meaning two axles with a total weight capacity of 6000 pounds.
14. **Suspension** - Protects the trailer chassis from shocks transmitted through the wheels. Types of suspension used are leaf, Q-flex, and air ride.
15. **Electrical** - Electrical connectors (looms) are provided with the trailer so the brake lights and turn signals can be connected to the towing vehicle.
16. **Application** - Indicates which units can be employed on a particular trailer.

Brakes

Trailer brakes should be inspected the **first 200 miles** of operation. This will allow the brake shoes and drums to seat properly. After the first 200 mile interval, inspect the brakes **every 3,000 miles**. If driving over rough terrain, inspect the brakes more frequently.

Figure 44 displays the major hydraulic surge brake components that will require inspection and maintenance. Please inspect these components as required using steps 1 through 8 and Table 15 as listed below:

Brake Adjustment

1. Place the trailer on jack stands. Make sure the jack stands are placed on secure level ground.
2. Check the wheel and drum for free rotation.
3. Remove the adjusting hole cover from the adjusting slot at the bottom brake backing plate.
4. With a screwdriver or standard adjusting tool, rotate the star wheel of the adjuster assembly to expand the brake shoes.
5. Adjust the brake shoes outward until the pressure of the lining against the wheel drum makes the wheel difficult to turn.
6. Adjust, rotate the star wheel in the opposite direction until the wheel rotates freely with slight lining drag.
7. Replace the adjusting hole cover and lower the trailer to the ground.
8. Repeat steps 1 through 7 on the remaining brakes.

Hydraulic Surge Brakes

Hydraulic surge brakes (Figure 44) should not require any special attention with the exception of routine maintenance such as shoe and lining replacement. Brake lines should be periodically checked for cracks, kinks, or blockage.

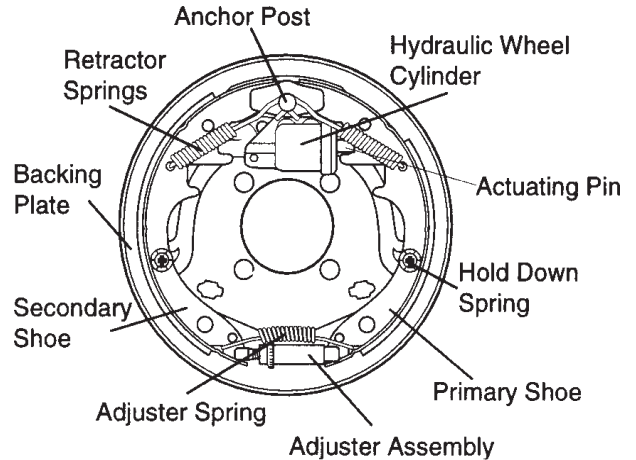

Figure 44. Hydraulic Brake Components

Actuator

Hydraulic surge braking requires the installation of an actuator at the tongue of the trailer. Remember the **surge** or **push** of the trailer toward the tow vehicle automatically synchronizes the trailer brakes with the tow vehicle brakes. As the trailer pushes against the tow vehicle the actuator telescopes together and applies force to the master cylinder, supplying hydraulic pressure to the trailer brakes.

Periodically check and test the surge “**actuator**” to make sure that it is functioning correctly. Never use an undersize actuator.

Table 12. Hydraulic Brake Troubleshooting		
Symptom	Possible Cause	Solution
No Brakes	Brake line broken or kinked?	Repair or replace.
Weak Brakes or Brakes Pull to One Side	Brake lining glazed?	Reburnish or replace.
	Trailer overloaded?	Correct weight.
	Brake drums scored or grooved?	Machine or replace.
	Tire pressure correct?	Inflate all tires equally.
	Tires unmatched on the same axle?	Match tires.
Locking Brakes	Brake components loose, bent or broken?	Replace components.
	Brake drums out-of-round?	Replace.
Noisy Brakes	System lubricated?	Lubricate.
	Brake components correct?	Replace and correct.
Dragging Brakes	Brake lining thickness incorrect or not adjusted correctly?	Install new shoes and linings.
	Enough brake fluid or correct fluid?	Replace rubber parts fill with dot 4 fluid.

Tires/Wheels/Lug Nuts

Tires and wheels are a very important and critical components of the trailer. When specifying or replacing the trailer wheels it is important the wheels, tires, and axle are properly matched.

! CAUTION - EYESIGHT HAZARD

ALWAYS wear safety glasses when removing or installing force fitted parts. Failure to comply may result in serious injury.



! CAUTION - REPAIRING TRAILER WHEELS







DO NOT attempt to repair or modify a wheel. **DO NOT** install in inner tube to correct a leak through the rim. If the rim is cracked, the air pressure in the inner tube may cause pieces of the rim to explode (break off) with great force and cause serious eye or bodily injury.



Tire Wear/Inflation

Tire inflation pressure is the most important factor in tire life. Pressure should be checked cold before operation **DO NOT** bleed air from tires when they are **hot!** Check inflation pressure weekly during use to insure the maximum tire life and tread wear.

Table 13 (Tire Wear Troubleshooting) will help pinpoint the causes and solutions of tire wear problems.

TABLE 13. TIRE WEAR TROUBLESHOOTING			
WEAR PATTERN		CAUSE	SOLUTION
	Center Wear	Over Inflation.	Adjust pressure to particular load per tire manufacturer.
	Edge Wear	Under Inflation.	Adjust pressure to particular load per tire manufacturer.
	Side Wear	Loss of camber or overloading.	Make sure load does not exceed axle rating. Align wheels.
	Toe Wear	Incorrect toe-in.	Align wheels.
	Cupping	Out-of-balance.	Check bearing adjustment and balance tires.
	Flat Spots	Wheel lockup & tire skidding.	Avoid sudden stops when possible and adjust brakes.

Suspension

The **leaf suspension** springs and associated components (Figure 45) should be visually inspected every 6,000 miles for signs of excessive wear, elongation of bolt holes, and loosening of fasteners. Replace all damaged parts (suspension) immediately. Torqued suspension components as detailed in Table 14.

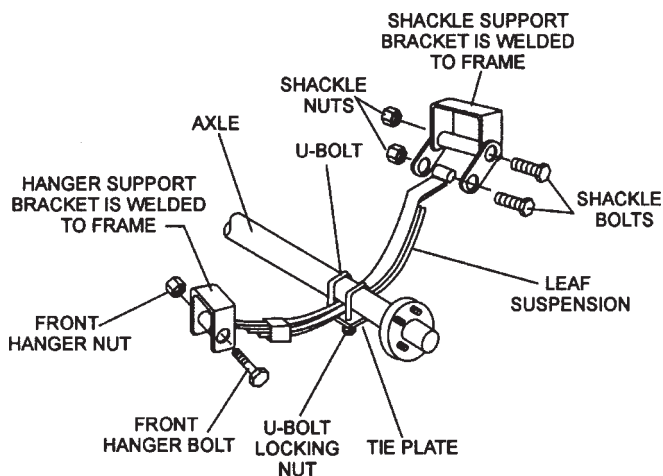

Figure 45. Major Suspension Components

Table 14. Suspension Torque Requirements

Item	Torque (Ft.-Lbs.)
3/8" U-BOLT	MIN-30 MAX-35
7/16" U-BOLT	MIN-45 MAX-60
1/2" U-BOLT	MIN-45 MAX-60
SHACKLE BOLT SPRING EYE BOLT	SNUG FIT ONLY. PARTS MUST ROTATE FREELY. LOCKING NUTS OR COTTER PINS ARE PROVIDED TO RETAIN NUT-BOLT ASSEMBLY.
SHOULDER TYPE SHACKLE BOLT	MIN-30 MAX-50

Lug Nut Torque Requirements

It is extremely important to apply and maintain proper wheel mounting torque on the trailer. Be sure to use only the fasteners matched to the cone angle of the wheel. Proper procedure for attachment of the wheels is as follows:

1. Start all wheel lug nuts by hand.
2. Torque all lug nuts in sequence (see Figure 46). **DO NOT** torque the wheel lug nuts all the way down. Tighten each lug nut in 3 separate passes as defined by Table 15.
3. After first road use, retorque all lug nuts in sequence. Check all wheel lug nuts periodically.

Table 15. Tire Torque Requirements

Wheel Size	First Pass FT-LBS	Second Pass FT-LBS	Third Pass FT-LBS
12"	20-25	35-40	50-65
13"	20-25	35-40	50-65
14"	20-25	50-60	90-120
15"	20-25	50-60	90-120
16"	20-25	50-60	90-120

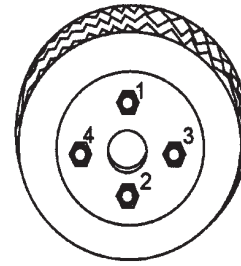

4-LUG NUTS

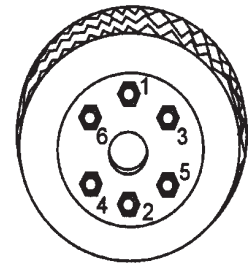

6-LUG NUTS

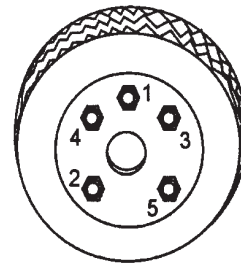

5-LUG NUTS

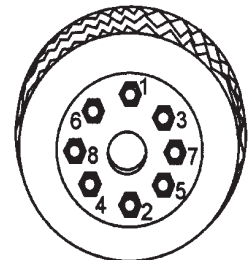

8-LUG NUTS

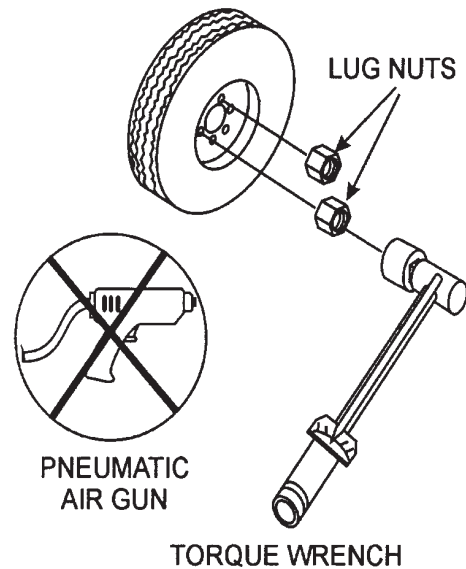
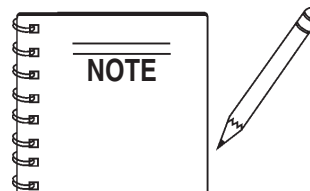

Figure 46. Wheel Lug Nuts Tightening Sequence



NEVER use an pneumatic air gun to tighten wheel lug nuts.

DCA-56SPX — TRAILER WIRING DIAGRAM

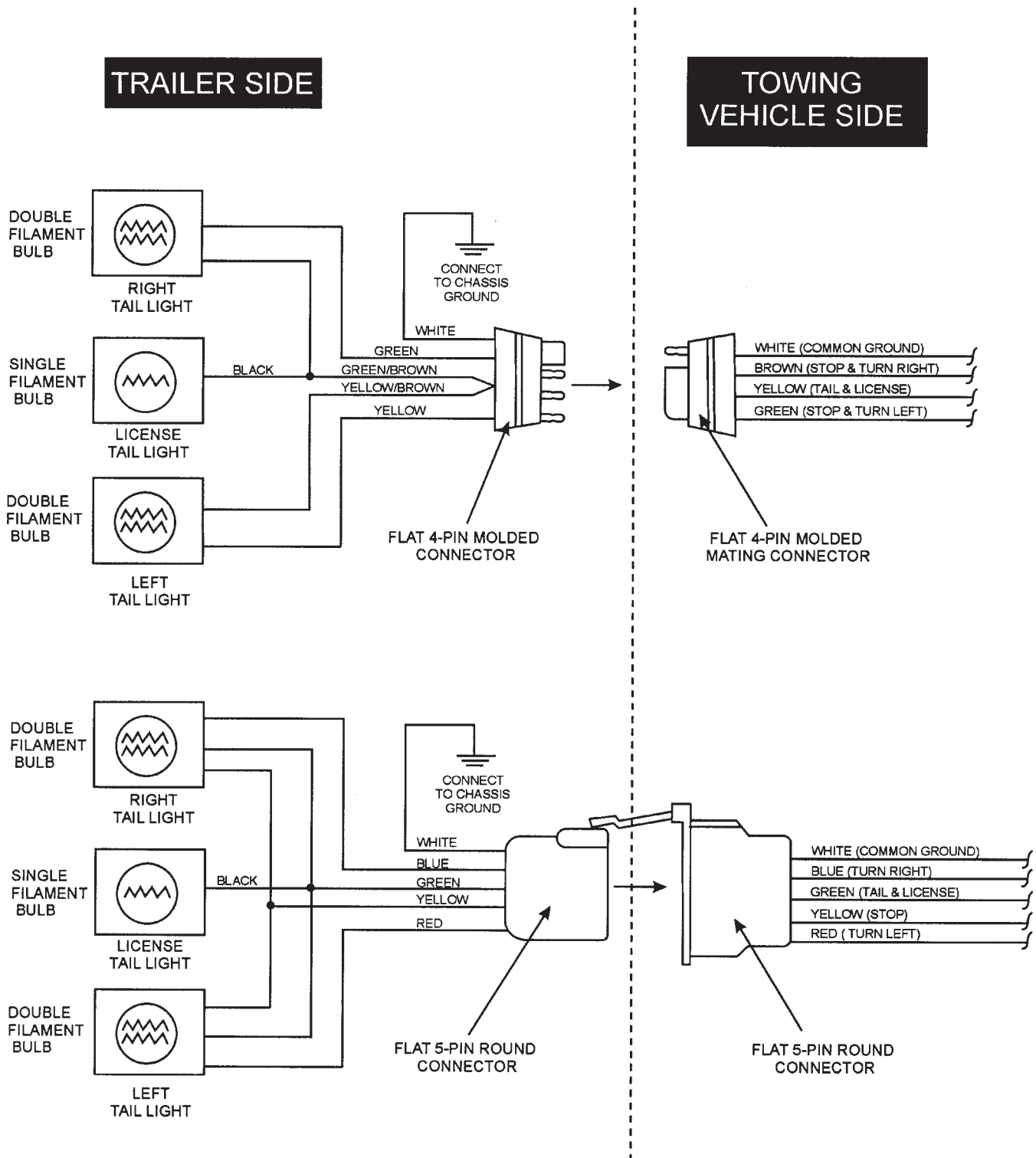
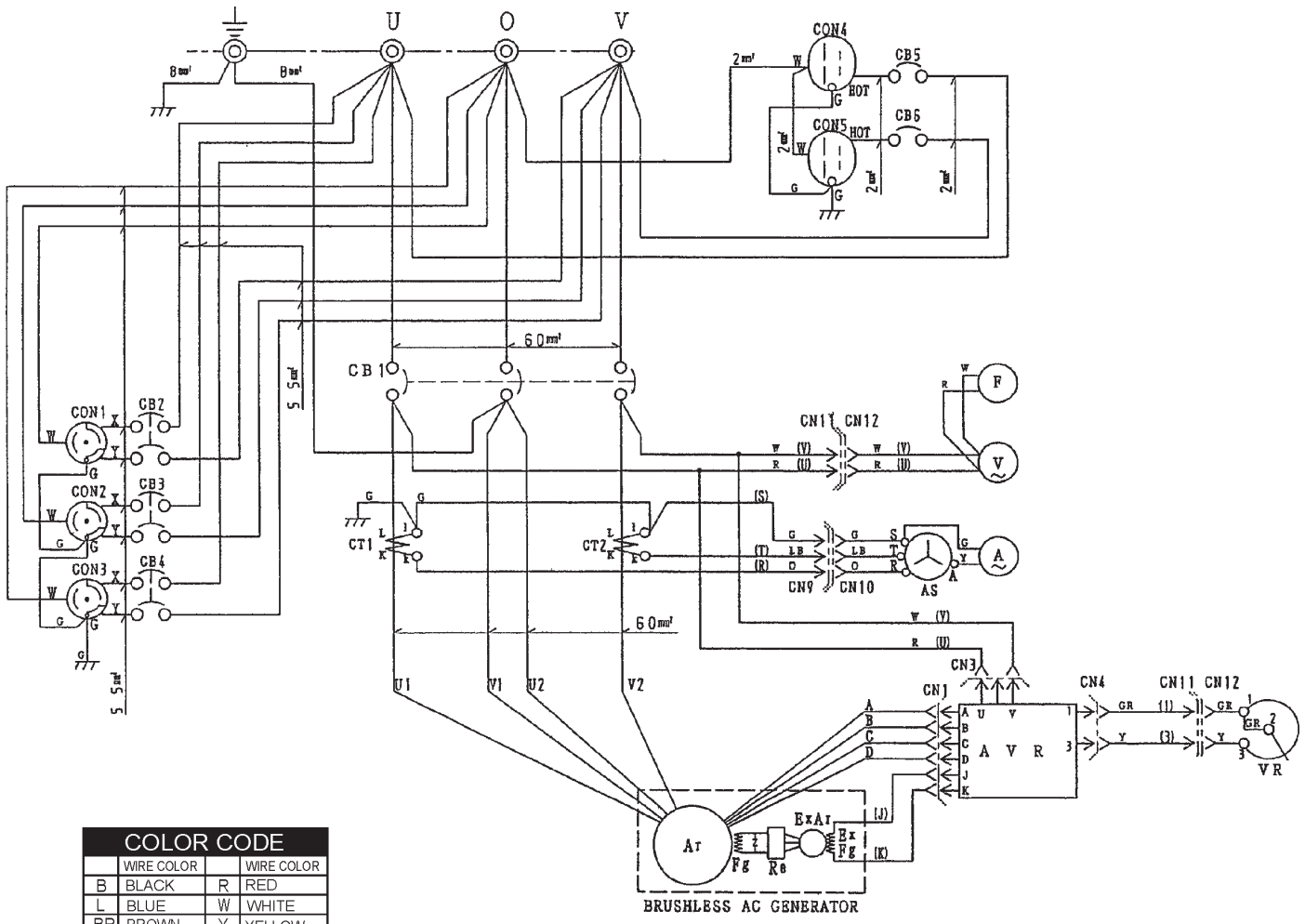

Figure 47. Trailer/Towing Vehicle Wiring Diagram

DCA-56SPX — GENERATOR WIRING DIAGRAM



COLOR CODE			
WIRE COLOR	WIRE COLOR	WIRE COLOR	WIRE COLOR
B	BLACK	R	RED
L	BLUE	W	WHITE
BR	BROWN	Y	YELLOW
G	GREEN	LB	LIGHT BLUE
GR	GRAY	LG	LIGHT GREEN
V	VIOLET	O	ORANGE
P	PINK		

SYMBOL	DESIGNATION
Ar	MAIN GENERATOR ARMATURE WINDING
Fg	MAIN GENERATOR FIELD WINDING
ExAr	EXCITER ARMATURE WINDING
ExFg	EXCITER FIELD WINDING
Re	RECTIFIER
AVR	AUTOMATIC VOLTAGE REGULATOR
VR	VOLTAGE REGULATOR (RHEOSTAT)
CT 1,2	CURRENT TRANSFORMER
AS	CHANGE-OVER SWITCH, AMMETER
A	AC AMMETER
V	AC VOLTMETER
F	FREQUENCY METER
CB1	CIRCUIT BREAKER
CB2, 3, 4	CIRCUIT BREAKER
CB5, 6	CIRCUIT BREAKER
CON1, 2, 3	RECEPTACLE
CON4, 5	RECEPTACLE

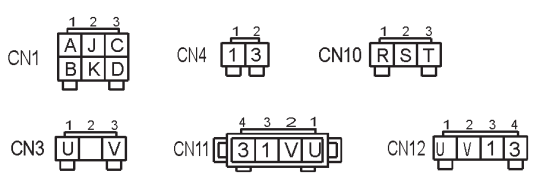

Notice:
 1. With no designation use KIV1 : 1.25 mm² lead of designated color.

Figure 48. Generator Wiring Diagram

DCA-56SPX — ENGINE WIRING DIAGRAM

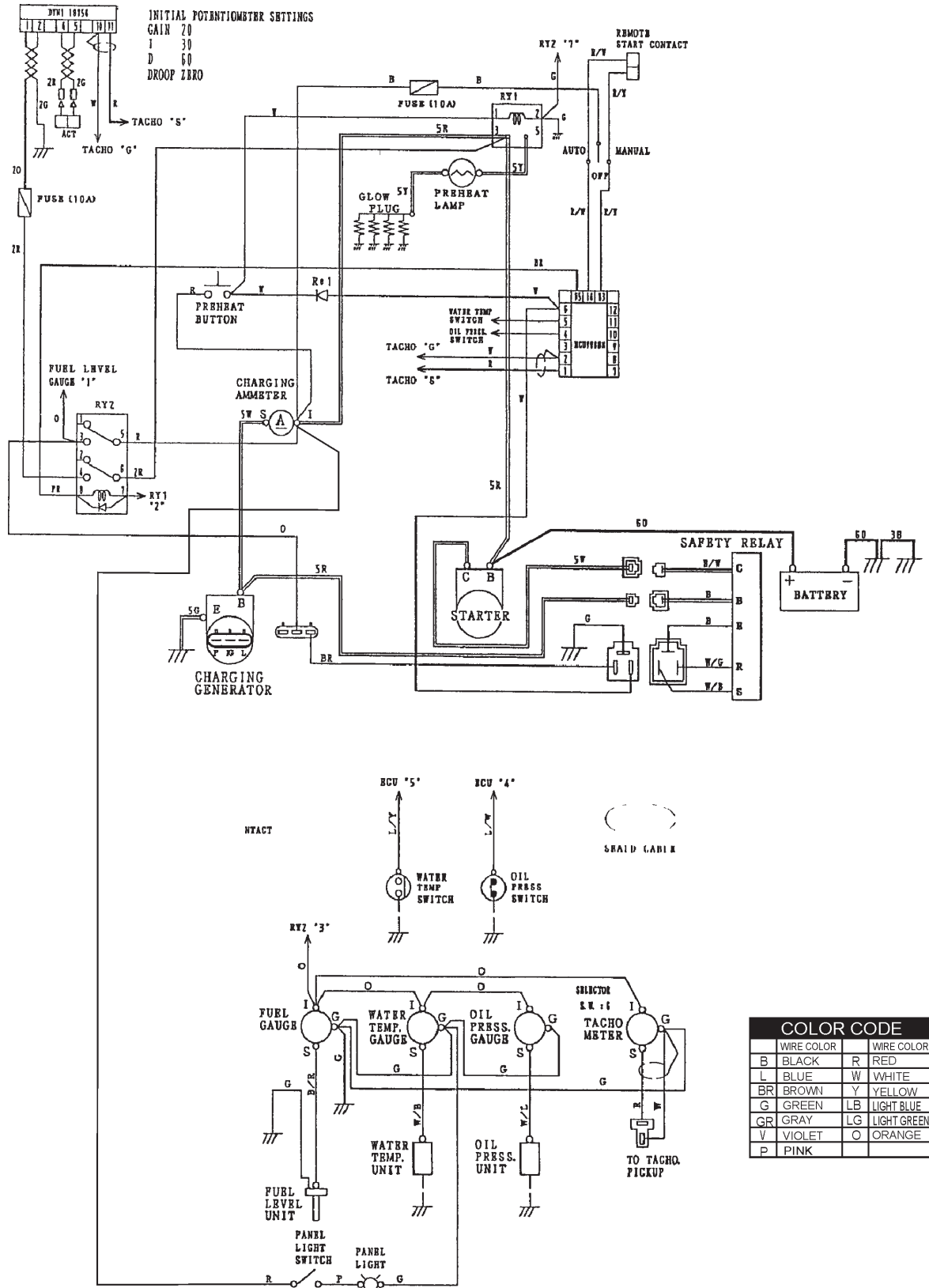

Figure 49. Engine Wiring Diagram

DCA-56SPX — TROUBLESHOOTING (ENGINE)

Practically all breakdowns can be prevented by proper handling and maintenance inspections, but in the event of a breakdown, use Table 16 shown below for diagnosis of the engine. If the problem cannot be remedied, consult our company's business office or service plant.

TABLE 16. ENGINE TROUBLESHOOTING

SYMPTOM	POSSIBLE PROBLEM	SOLUTION
Engine does not start.	No fuel?	Replenish fuel.
	Air in the fuel system?	Bleed system.
	Water in the fuel system?	Remove water from fuel tank.
	Fuel pipe clogged?	Clean fuel pipe.
	Fuel filter clogged?	Clean or change fuel filter.
	Excessively high viscosity of fuel or engine oil at low temperature?	Use the specified fuel or engine oil.
	Fuel with low cetane number?	Use the specified fuel.
	Fuel leak due to loose injection pipe retaining nut?	Tighten nut.
	Incorrect injection timing?	Adjust.
	Fuel cam shaft worn?	Replace.
	Injection nozzle clogged?	Clean injection nozzle.
	Injection pump malfunctioning?	Repair or replace.
	Seizure of crankshaft, camshaft, piston, cylinder liner or bearing?	Repair or replace.
	Compression leak from cylinder?	Replace head gasket, tighten cylinder head bolt, glow plug and nozzle holder.
	Improper valve timing?	Correct or replace timing gear.
	Piston ring and liner worn?	Replace.
Excessive valve clearance?	Adjust.	
Starter does not run.	Battery discharged?	Charge battery.
	Starter malfunctioning?	Repair or replace.
	Key switch malfunctioning?	Repair or replace.
	Wiring disconnected?	Connect wiring.

DCA-56SPX — TROUBLESHOOTING (ENGINE)

TABLE 16. ENGINE TROUBLESHOOTING (CONTINUED)

SYMPTOM	POSSIBLE PROBLEM	SOLUTION
Engine revolution is not smooth.	Fuel filter clogged or dirty?	Clean or change.
	Air cleaner clogged?	Clean or change.
	Fuel leak due to loose injection pipe retaining nut?	Tighten nut.
	Injection pump malfunctioning?	Repair or replace.
	Incorrect nozzle opening pressure?	Adjust.
	Injection nozzle stuck or clogged?	Repair or replace.
	Fuel over flow pipe clogged?	Clean.
	Governor malfunctioning?	Repair.
Either white or blue exhaust gas is observed.	Excessive engine oil?	Reduce to the specified level.
	Piston ring and liner worn or stuck?	Repair or replace.
	Incorrect injection timing?	Adjust.
	Deficient compression?	Adjust top clearance.
Either black or dark gray exhaust gas is observed.	Overload?	Lessen the load.
	Low grade fuel used?	Use the specified fuel.
	Fuel filter clogged?	Clean or change.
	Air cleaner clogged?	Clean or change.
	Deficient nozzle injection?	Repair or replace the nozzle.
Deficient output.	Incorrect injection timing?	Adjust.
	Engine's moving parts seem to be seizing?	Repair or replace.
	Uneven fuel injection?	Repair or replace the injection pump.
	Deficient nozzle injection?	Repair or replace the nozzle.
	Compression leak?	Replace head gasket, tighten cylinder head bolt, glow plug and nozzle holder.

DCA-56SPX — TROUBLESHOOTING (GENERATOR)

Practically all breakdowns can be prevented by proper handling and maintenance inspections, but in the event of a breakdown, use Table 17 shown below for diagnosis of the generator. If the problem cannot be remedied, consult our company's business office or service plant.

TABLE 17. GENERATOR TROUBLESHOOTING

SYMPTOM	POSSIBLE PROBLEM	SOLUTION
No Voltage Output	AC Voltmeter defective?	Check output voltage using a voltmeter.
	Is wiring connection loose?	Check wiring and repair.
	Is AVR defective?	Replace if necessary.
	Defective Rotating Rectifier?	Check and replace.
	Defective Exciter Field?	Check for 17.3 ohms across J & K on CN1
Low Voltage Output	Is engine speed correct?	Turn engine throttle lever to "High".
	Is wiring connections loose?	Check wiring and repair.
	Defective AVR?	Replace if necessary.
High Voltage Output	Is wiring connections loose?	Check wiring and repair.
	Defective AVR?	Replace if necessary.
Circuit Breaker Tripped	Short Circuit in load?	Check load and repair.
	Over current?	Confirm load requirements and reduce.
	Defective circuit breaker?	Check and replace.
	Over current Relay actuated?	Confirm load requirement and replace.

DCA-56SPX — TROUBLESHOOTING (ENGINE CONTROLLER)

Practically all breakdowns can be prevented by proper handling and maintenance inspections, but in the event of a breakdown, use Table 18 (Engine Controller Troubleshooting) as a basic guideline for troubleshooting the Microprocessor Engine Controller unit (MPEC). If the problem cannot be remedied, consult our company's business office or service plant.

TABLE 18. ENGINE CONTROLLER TROUBLESHOOTING (MPEC)

SYMPTOM	POSSIBLE PROBLEM	SOLUTION
Low oil pressure light is on.	Low oil level?	Fill oil level.
	Oil pressure sending unit failure?	Replace oil pressure sending unit.
	Time delay malfunction in Controller?	Refer to dealer.
	Wire shorted?	Inspect/repair wire.
Low coolant level light is on. (Optionally Installed)	Low coolant level?	Fill coolant level.
	Sending unit failure?	Replace sending unit.
	Low battery voltage?	Replace/charge battery.
High coolant temperature light is on.	Fan belt tension incorrect?	Tighten/replace fan belt.
	Air flow is not circulation through radiator?	Clean/repair radiator grill.
	Doors open?	Close doors.
	Exhaust leaking?	Replace/repair gaskets or faulty part.
	Generator being overloaded?	Check/reduce load.
	Thermostat failure?	Replace thermostat.
	Air intake blocked?	Clear all air intakes.
	Temperature switch failure?	Replace temperature switch.
Overcrank light is on.	No or low Fuel?	Fill fuel level.
	Controller needs to be calibrated?	Refer to dealer.
Overspeed light is on.	RPM engine speed too high?	Adjust RPM.
	Governor actuator needs to be adjusted?	Adjust governor actuator.
	Governor controller needs to be adjusted?	Adjust governor controller.
	Engine Controller needs to be calibrated?	Refer to dealer.
Loss of MPU light(s) or on.	Magnetic pick up out of adjustment?	Adjust magnetic pick up.
	Magnetic pick up dirty?	Clean magnetic pick up.

DCA-56SPX — EXPLANATION OF CODE IN REMARKS COLUMN

The following section explains the different symbols and remarks used in the Parts section of this manual. Use the help numbers found on the back page of the manual if there are any questions.

NOTICE

The contents and part numbers listed in the parts section are subject to change **without notice**. Multiquip does not guarantee the availability of the parts listed.

SAMPLE PARTS LIST

NO.	PART NO.	PART NAME	QTY.	REMARKS
1	12345	BOLT.....	1	INCLUDES ITEMS W/%
2%		WASHER, 1/4 IN.....		NOT SOLD SEPARATELY
2%	12347	WASHER, 3/8 IN....	1	MQ-45T ONLY
3	12348	HOSE		A/R ...MAKE LOCALLY
4	12349	BEARING	1	S/N 2345B AND ABOVE

NO. Column

Unique Symbols — All items with same unique symbol

(@, #, +, %, or >) in the number column belong to the same assembly or kit, which is indicated by a note in the “Remarks” column.

Duplicate Item Numbers — Duplicate numbers indicate multiple part numbers, which are in effect for the same general item, such as different size saw blade guards in use or a part that has been updated on newer versions of the same machine.

NOTICE

When ordering a part that has more than one item number listed, check the remarks column for help in determining the proper part to order.

PART NO. Column

Numbers Used — Part numbers can be indicated by a number, a blank entry, or TBD.

TBD (To Be Determined) is generally used to show a part that has not been assigned a formal part number at the time of publication.

A blank entry generally indicates that the item is not sold separately or is not sold by Multiquip. Other entries will be clarified in the “Remarks” Column.

QTY. Column

Numbers Used — Item quantity can be indicated by a number, a blank entry, or A/R.

A/R (As Required) is generally used for hoses or other parts that are sold in bulk and cut to length.

A blank entry generally indicates that the item is not sold separately. Other entries will be clarified in the “Remarks” Column.

REMARKS Column

Some of the most common notes found in the “Remarks” Column are listed below. Other additional notes needed to describe the item can also be shown.

Assembly/Kit — All items on the parts list with the same unique symbol will be included when this item is purchased.

Indicated by:

“INCLUDES ITEMS W/(unique symbol)”

Serial Number Break — Used to list an effective serial number range where a particular part is used.

Indicated by:

“S/N XXXXX AND BELOW”

“S/N XXXX AND ABOVE”

“S/N XXXX TO S/N XXX”

Specific Model Number Use — Indicates that the part is used only with the specific model number or model number variant listed. It can also be used to show a part is NOT used on a specific model or model number variant.

Indicated by:

“XXXXX ONLY”

“NOT USED ON XXXX”

“Make/Obtain Locally” — Indicates that the part can be purchased at any hardware shop or made out of available items. Examples include battery cables, shims, and certain washers and nuts.

“Not Sold Separately” — Indicates that an item cannot be purchased as a separate item and is either part of an assembly/kit that can be purchased, or is not available for sale through Multiquip.

DCA-56SPX WHISPERWATT GENERATOR W/ISUZU FF-4BGIT DIESEL ENGINE 1 TO 3 UNITS

<u>Qty.</u>	<u>P/N</u>	<u>Description</u>
1	B5310500003	HOSE, RADIATOR UPPER
1	B5310500103	HOSE, RADIATOR LOWER
1	0845500104	FUEL CAP
1	0602122272	UNIT, OIL PRESSURE
1	0602123260	UNIT, WATER TEMPERATURE
6	1132400791	FILTER, FUEL CARTRIDGE
6	1132402321	FILTER, OIL CARTRIDGE
3	0602046365	FILTER, AIR (ELEMENT)
1	0601870440	CIRCUIT BREAKER, 1P, 120V @ 20A
1	0601870441	CIRCUIT BREAKER, 2P, 250V @ 50A
1	LY2DDC12V	RELAY
1	8972333820	FAN BELT
1	0601820626	AUTOMATIC VOLTAGE REGULATOR
1	0601840073	RHEOSTAT
1	0601840121	KNOB, RHEOSTAT
2	0601802149	FUSE, 10A

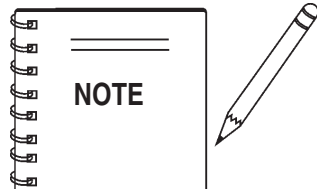

Part number on this Suggested Spare Parts list may supercede/replace the P/N shown in the text pages of this book.

DCA-56SPX — GENERATOR ASSY.

GENERATOR ASSY.

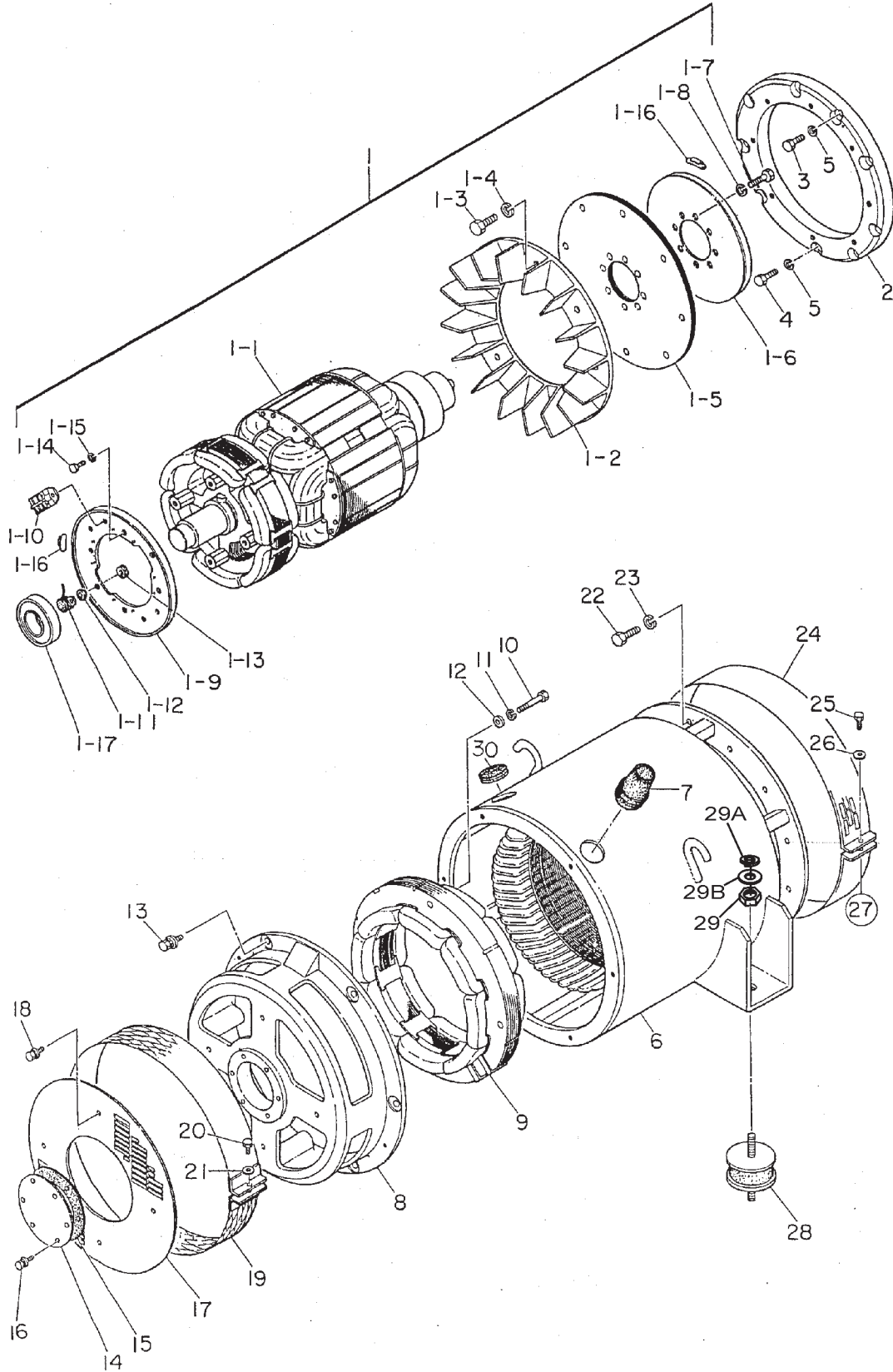

DCA-56SPX — GENERATOR ASSY.

GENERATOR ASSY.

<u>NO.</u>	<u>PART NO.</u>	<u>PART NAME</u>	<u>QTY.</u>	<u>REMARKS</u>
1	B4110100102	ROTOR ASSY.	1	
1-1		FIELD ASSY.	1	
1-2	B101070033	FAN	1	
1-3	0012110035	HEX HEAD BOLT	8	
1-4	0042510000	WASHER, LOCK	8	
1-5	8101611004	COUPLING DISK	5	
1-6	8101015003	BALANCING PLATE	1	PURCHASE 1-10 AS A SET
1-7	0012110030	HEX HEAD BOLT	8	
1-8	0042510000	WASHER, LOCK	8	
1-9	8101026013	RECTIFIER SET PLATE	1	PURCHASE 1-16 AS A SET
1-10	0601821349	RECTIFIER	2	
1-11	0601822601	SURGE ABSORBER	1	
1-12	8001020004	INSULATOR WASHER	1	
1-14	0010110020	HEX HEAD BOLT	4	
1-15	0040010000	WASHER, LOCK	4	
1-16	0601000209	BALANCING WEIGHT KIT	1	
1-17	0071906311	BEARING	1	
2	8391614003	COUPLING RING	1	
3	8051653004	REAMER BOLT	2	
4	0012110030	HEX HEAD BOLT	7	
5	0042510000	WASHER, LOCK	8	
6	8111340513	STATOR ASSY	1	
7	0845041804	GROMMET	1	
8	8101315202	END BRACKET	1	
9	8101350013	FIELD ASSY. EXCITER	1	
10	0012110070	HEX HEAD BOLT	4	
11	0042610000	WASHER, LOCK	4	
12	0041210000	WASHER, FLAT	4	
13	0017110035	HEX HEAD BOLT	6	
14	8101310014	BEARING COVER	1	
15	8131312014	BEARING GASKET	1	
16	0016906012	HEX HEAD BOLT	6	
17	8101331003	END BRACKET COVER	1	
18	0016906012	HEX HEAD BOLT	4	
19	8101333003	END BRACKET COVER	1	
20	0340406040	HEX HEAD BOLT	1	
21	0041606000	WASHER, FLAT	1	
22	0010310025	HEX HEAD BOLT	12	
23	0042510000	WASHER, LOCK	12	
24	8111332014	FAN COVER	1	
25	0340406040	HEX HEAD BOLT	1	
26	0041606000	WASHER, FLAT	1	
27	0600815000	NUT	1	
28	0605000010	RUBBER SUSPENSION	2	
29	0030012000	HEX NUT	2	
29A	0040012000	WASHER, LOCK	2	
29B	0041212000	WASHER, FLAT	2	
30	0801358204	GROMMET	1	

DCA-56SPX—CONTROL BOX ASSY.

CONTROL BOX ASSY. (S/N 7800001~7800129)

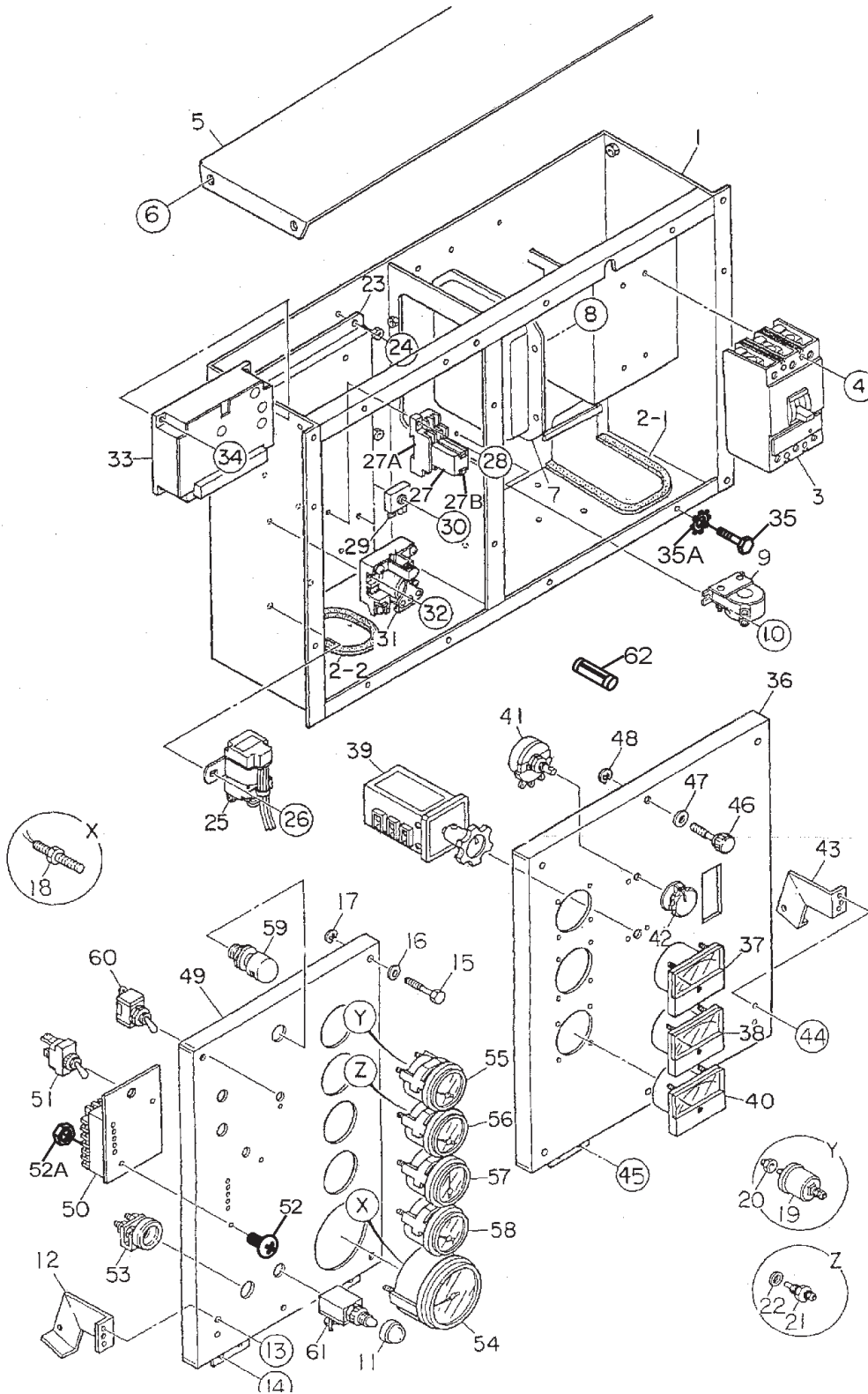

DCA-56SPX— CONTROL BOX ASSY.

CONTROL BOX ASSY.

<u>NO.</u>	<u>PART NO.</u>	<u>PART NAME</u>	<u>QTY.</u>	<u>REMARKS</u>
1	B4214003802	CONTROL BOX	1	
2-1	0226900680	EDGING	1	
2-2	0226900240	EDGING	1	
3	0601808822	CIRCUIT BREAKER, 3P@250 AMPS	1	
4	0021005080	MACHINE SCREW	4	
5	B5213500203	CONTROL BOX COVER	1	
6	0016906015	HEX HEAD BOLT	5	
7	0601820626	AUTOMATIC VOLTAGE REGULATOR	1	
8	0027105016	MACHINE SCREW	4	
9	0601809666	CURRENT TRANSFORMER, 300/5A	2	
10	0017105020	MACHINE SCREW	4	
11	0601831586	CAP	1	
12	B5223100104	STOPPER	1	
13	0027105010	MACHINE SCREW	2	
14	0027105010	MACHINE SCREW	4	
15	B9221100104	SET SCREW	2	
16	0041206000	WASHER, FLAT	2	
17	0080200005	SNAP RING	2	
18	0602120480	TACHOMETER PICK UP	1	
19	0602122272	OIL PRESSURE UNIT	1	
20	B9200100004	ADAPTER	1	
21	0602123260	WATER TEMPERATURE UNIT	1	
22	1825530401	PACKING	1	REPLACES P/N 0602021109
23	B5260500204	ELECTRIC PARTS BRACKET	1	
24	0016906015	HEX HEAD BOLT	4	
25	1825530401	STARTER RELAY	1	REPLACES P/N 0602200304
26	0016906016	MACHINE SCREW	2	
27	LY2DDC12V	RELAY	1	REPLACES P/N 0601827656
27A	PTF08AE	BASE	1	REPLACES P/N 0601823109
27B	PYCA1	CLIP	2	REPLACES P/N 0601824400
28	0027104020	MACHINE SCREW	2	
29	0601823240	RECTIFIER	1	
30	0027104020	MACHINE SCREW	1	
31	0601827680	STARTER RELAY	1	
32	0027104020	MACHINE SCREW	2	
33	0602202546	CONTROLLER (EGS) DYN1	1	
34	0027105016	MACHINE SCREW	4	
35	0017106016	HEX HEAD BOLT	16	
35A	0040506000	TOOTHED WASHER	1	
36	B4224002903	CONTROL PANEL	1	
37	0601807641	FREQUENCY METER, 45~65Hz 240V	1	
38	0601806847	AC AMMETER, 0~300A	1	
39	0601801040	AMMETER CHANGE OVER SWITCH	1	

DCA-56SPX—CONTROL BOX ASSY.

CONTROL BOX ASSY. (S/N 7800001~7800129)

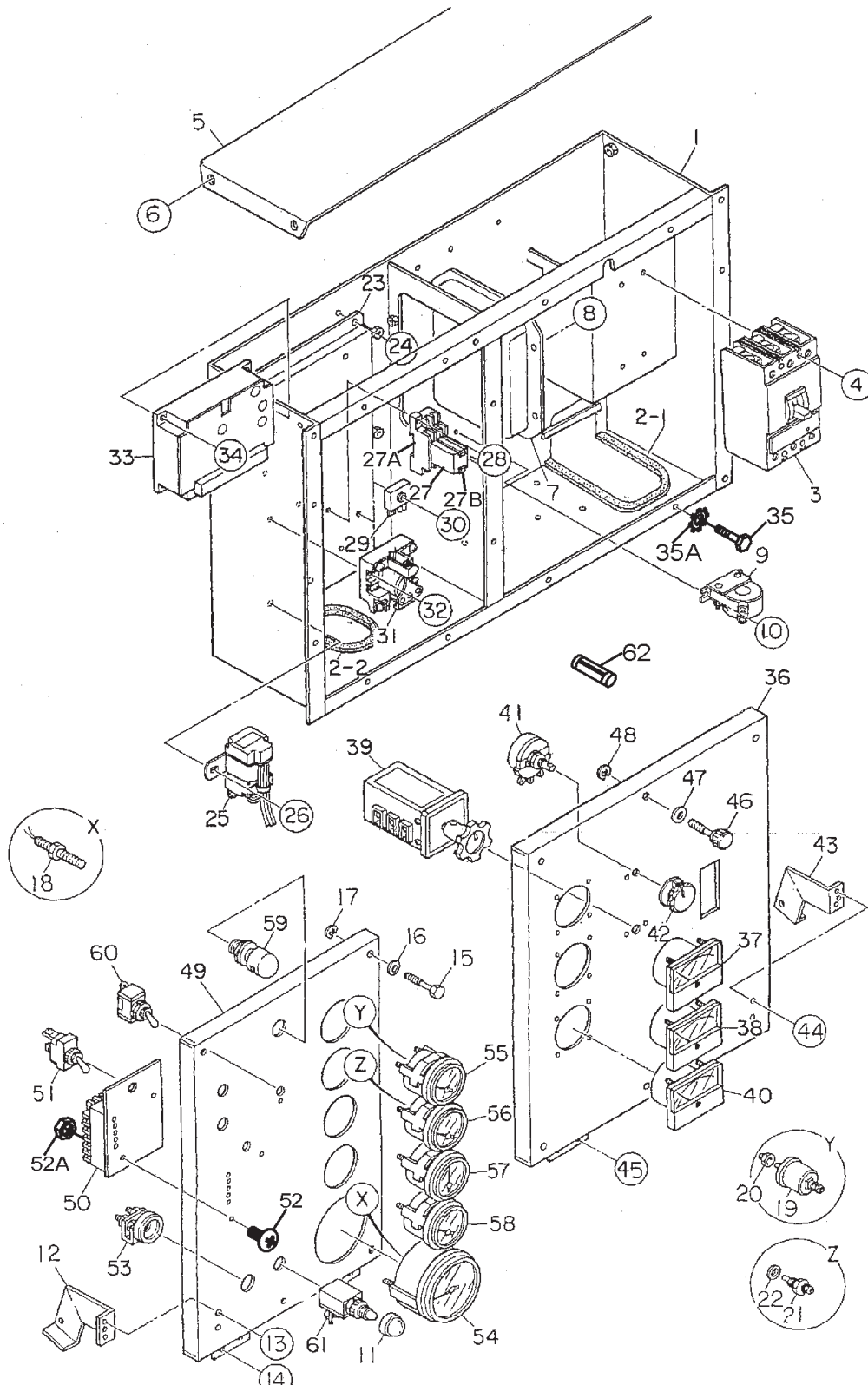

DCA-56SPX— CONTROL BOX ASSY.

CONTROL BOX ASSY.

<u>NO.</u>	<u>PART NO.</u>	<u>PART NAME</u>	<u>QTY.</u>	<u>REMARKS</u>
40	060180271	AC VOLTMETER, 0~300V	1	
41	0601840073	VOLTAGE REGULATOR, 2W 1K OHM	1	
42	0601840121	KNOB	1	
43	B5223100004	STOPPER	1	
44	0027105010	MACHINE SCREW	2	
45	0027105010	MACHINE SCREW	4	
46	0845056404	SET SCREW	1	
47	0041208000	WASHER, FLAT	1	
48	0080200007	SNAP RING	1	
49	B5351100804	ENGINE OPERATING PANEL	1	
50	0602202545	CONTROLLER, ECU-9988N	1	
51	0601831340	SWITCH	1	
52	0021004040	MACHINE SCREW	2	
52A	0207004000	HEX NUT	2	
53	0602202506	PREHEAT LAMP	1 ISUZU 894173-9480
54	0602120095	TACHOMETER	1	
55	0602122093	OIL PRESSURE GAUGE	1	
56	0602123090	WATER TEMPERATURE GAUGE	1	
57	0602121080	CHARGING AMMETER	1	
58	0602125090	FUEL GAUGE	1	
59	0601810141	PANEL LIGHT	1	
60	0601831330	PANEL LIGHT SWITCH	1	
61	0601831585	PREHEAT BUTTON	1	
62	0601802149	FUSE, 10A	2	

DCA-56SPX— ENGINE AND RADIATOR ASSY.

ENGINE AND RADIATOR ASSY.

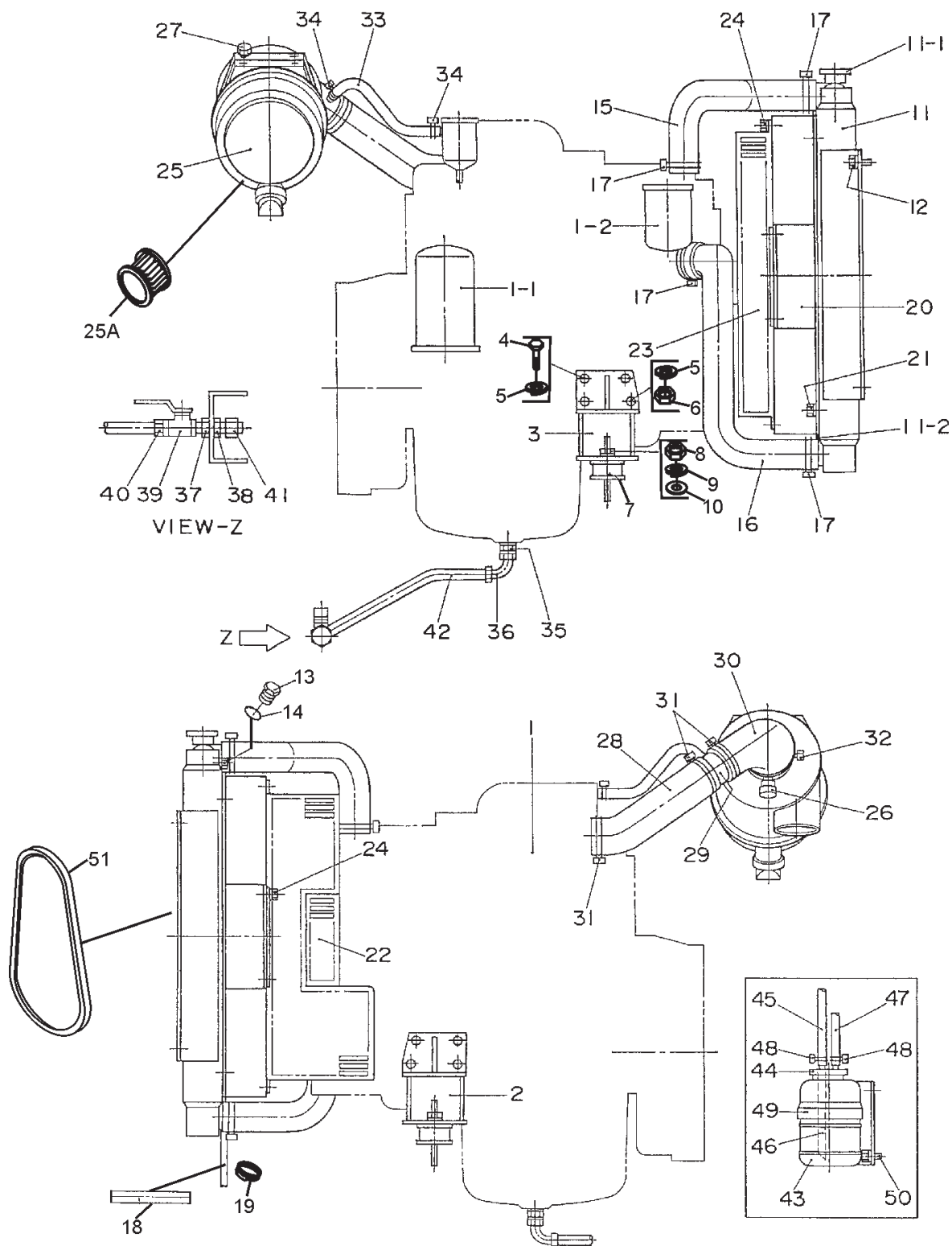

DCA-56SPX— ENGINE AND RADIATOR ASSY.

ENGINE & RADIATOR ASSY.

<u>NO.</u>	<u>PART NO.</u>	<u>PART NAME</u>	<u>QTY.</u>	<u>REMARKS</u>
1	B5923200034	ENGINE, FF-48G1T	1	
1-1	1132402321	OIL FILTER CARTRIDGE	1	REPLACES P/N 0602041216
1-2	1132400791	FUEL FILTER CARTRIDGE	1	REPLACES P/N 0602042407
2	3345112403	ENGINE FOOT	1	
3	3345112503	ENGINE FOOT	1	
4	0010710025	HEX HEAD BOLT	7	
5	0042510000	WASHER, LOCK	8	
6	0030410000	HEX NUT	1	
7	0605000009	RUBBER SUSPENSION	2	
8	0030012000	HEX NUT	2	
9	0040012000	WASHER, LOCK	2	
10	0041212000	WASHER, FLAT	2	
11	M2923200054	RADIATOR	1	
11-1	0602011062	CAP	1	
11-2	B5493100504	ACOUSTIC SHEET	2	
12	0017108020	HEX HEAD BOLT	6	
13	B9200200004	PLUG	1	
14	0150000016	O-RING	1	
15	B5310500003	RADIATOR HOSE	1	
16	B5310500103	RADIATOR HOSE	1	
17	0605515142	HOSE BAND	4	
18	0193601000	DRAIN HOSE	1	
19	0605515106	HOSE BAND	1	
20	B5310300003	FAN SHROUD	1	
21	0017108020	HEX HEAD BOLT	4	
22	B5310200003	FAN GUARD	1	
23	B5310200103	FAN GUARD	1	
24	0017108020	HEX HEAD BOLT	11	
25	0602046249	AIR CLEANER	1	
25A	0602046365	AIR CLEANER ELEMENT	1	
26	0602040690	AIR CLEANER INDICATOR	1	
27	0016908020	HEX HEAD BOLT	4	
28	B5373100204	AIR CLEANER HOSE	1	
29	B532600104	BLOWBY PIPE	1	
30	B5373100004	AIR CLEANER HOSE	1	
31	0605515143	HOSE BAND	3	
32	0605515211	HOSE BAND	1	
33	0191300500	BLOWBY HOSE	1	
34	0605515131	HOSE BAND	2	
35	0602022560	ADAPTER	1	
36	0602022561	90 DEGREE ELBOW	1	
37	0603306590	CONNECTOR	1	
38	0603300285	ROCKNUT	1	

DCA-56SPX— ENGINE AND RADIATOR ASSY.

ENGINE & RADIATOR ASSY.

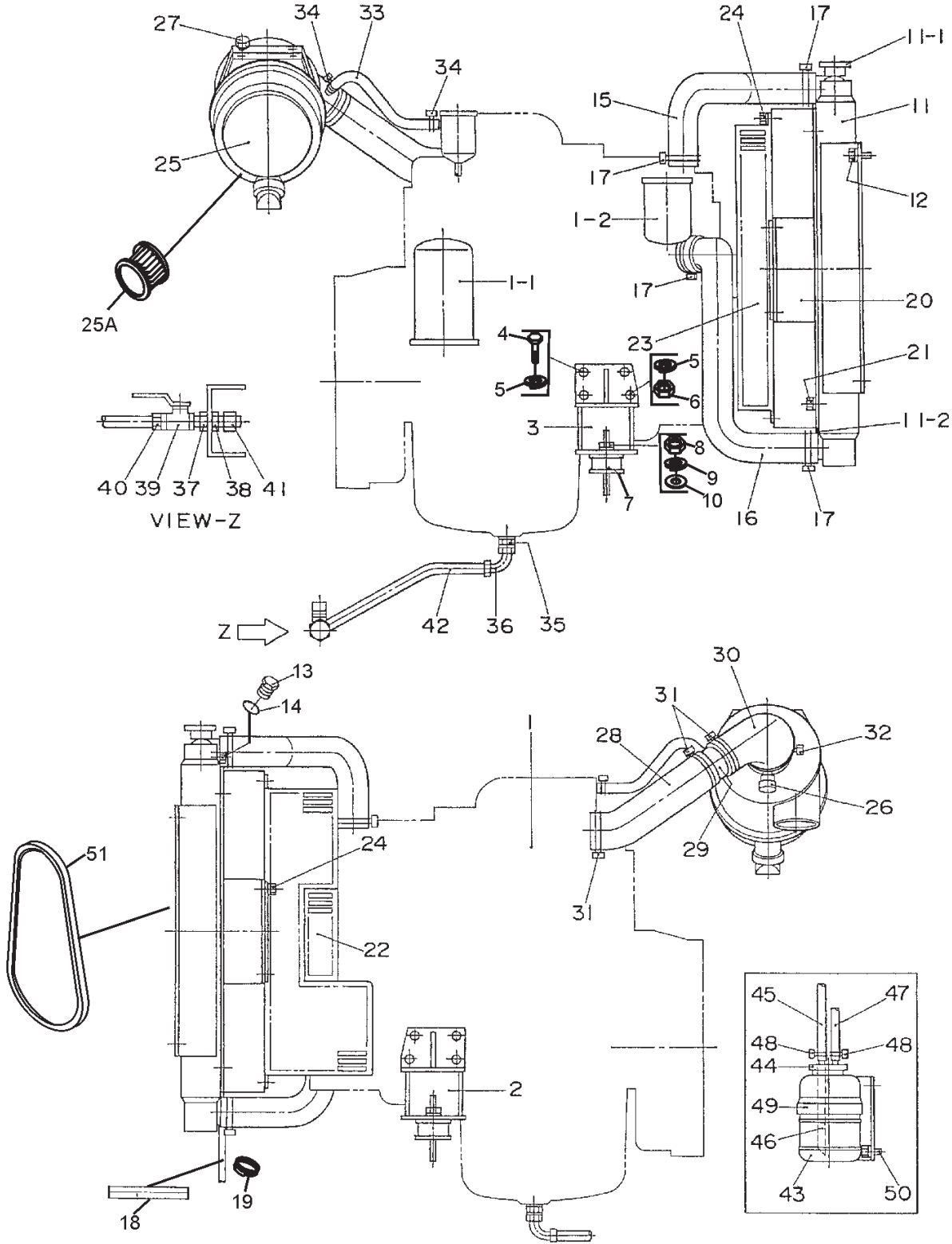

DCA-56SPX— ENGINE AND RADIATOR ASSY.

ENGINE AND RADIATOR ASSY.

<u>NO.</u>	<u>PART NO.</u>	<u>PART NAME</u>	<u>QTY.</u>	<u>REMARKS</u>
39	0605511395	VALVE	1	
40	0603306395	HOSE JOINT	1	
41	0602021070	CAP	1	
42	0269200500	DRAIN HOSE	1	
43	0845031303	RESERVE TANK	1	
44	0802081104	RESEREVE TANK CAP	1	
45	0199900400	HOSE	1	
46	0199900175	HOSE	1	
47	0193601800	HOSE	1	
48	0605515106	HOSE BAND	3	
49	B5316100204	RESERVE TANK BRACKET	1	
50	0017108020	HEX HEAD BOLT	2	
51	8972333820	FAN BELT	1	REPLACES P/N 0602011434

DCA-56SPX— OUTPUT TERMINAL ASSY.

OUTPUT TERMINAL ASSY.

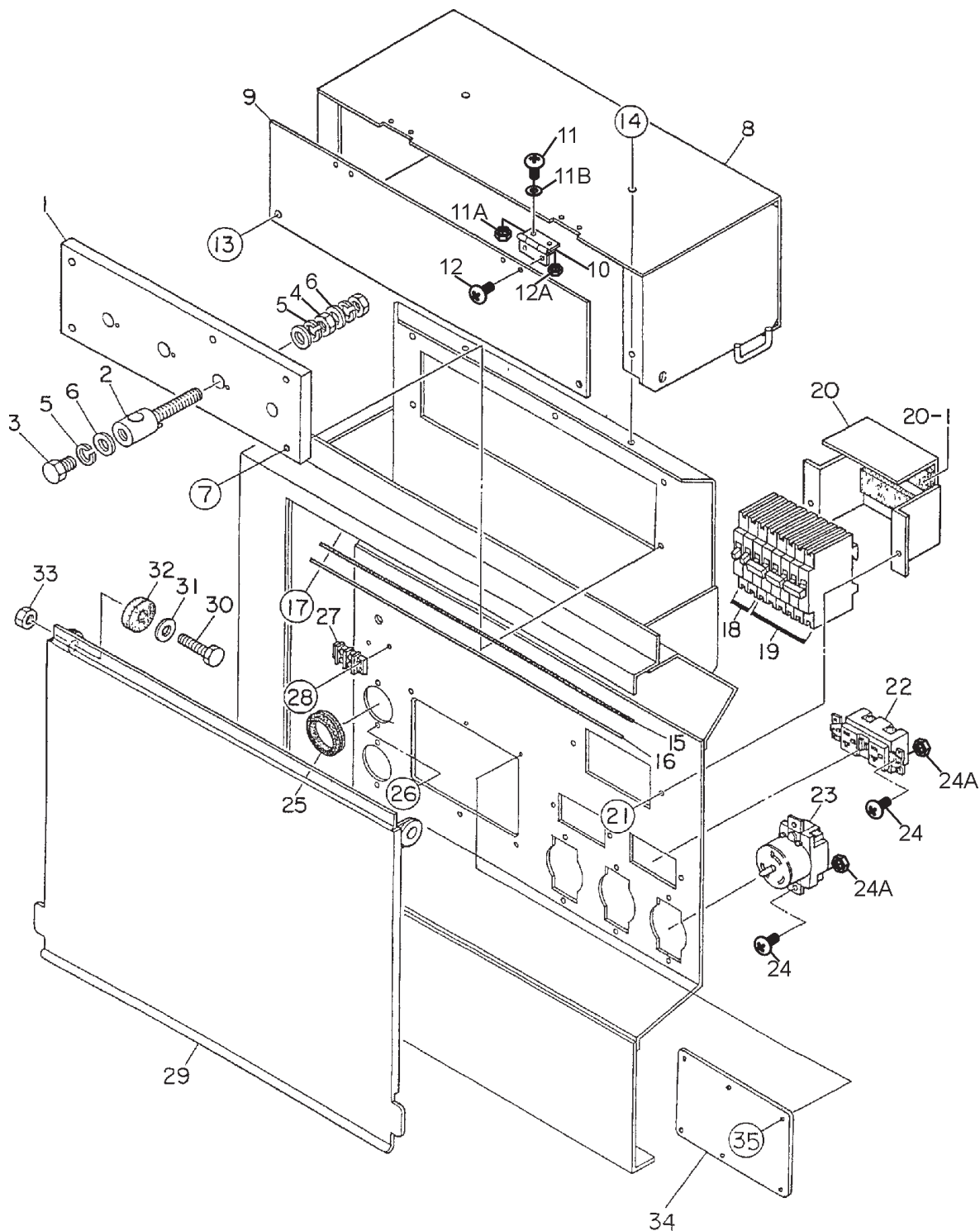

DCA-56SPX— OUTPUT TERMINAL ASSY.

OUTPUT TERMINAL ASSY.

<u>NO.</u>	<u>PART NO.</u>	<u>PART NAME</u>	<u>QTY.</u>	<u>REMARKS</u>
1	B4231700903	TERMINAL PANEL	1	
2	C9220100004	OUTPUT TERMINAL BOLT	4	
3	0801830804	TIE BOLT	4	
4	0039316000	HEX NUT	8	
5	0040016000	WASHER, LOCK	12	
6	0041416000	WASHER, FLAT	16	
7	0017108035	HEX HEAD BOLT	5	
8	B5236100503	TERMINAL COVER	1	
9	B5236100604	OUTPUT WINDOW	1	
10	0605010040	HINGE	2	
11	0027103010	MACHINE SCREW	4	
11A	0030003000	HEX NUT	4	
11B	0041203000	WASHER, FLAT	4	
12	0027103010	MACHINE SCREW	4	
12A	0030003000	HEX NUT	4	
13	0016906020	HEX HEAD BOLT	2	
14	0017106016	HEX HEAD BOLT	4	
15	B5236400004	CABLE OUTLET COVER	1	
16	B5236400104	CABLE OUTLET COVER SUPPORTER	1	
17	0016906020	HEX HEAD BOLT	6	
18	0601870440	CIRCUIT BREAKER, 1P 20A	2	
19	0601870441	CIRCUIT BREAKER, 2P 50A	3	
20	B5260700104	BREAKER FITTING COVER	1	
20-1	0222100100	CUSHION RUBBER	2	
21	0017106020	HEX HEAD BOLT	2	
22	0601812598	RECEPTACLE, GFCI125V 20AX2	2	
23	0601812565	RECEPTACLE, CS6369 250V 50A	3	
24	0027104016	MACHINE SCREW	10	
24A	0207004000	HEX NUT	10	
25	0601851780	GROMMET	2	
26	0027104016	MACHINE SCREW	2	
27	0601815194	TERMINAL	1	
28	0027104016	MACHINE SCREW	2	
29	B5236100403	TERMINAL COVER	1	
30	0010112045	HEX HEAD BOLT	2	
31	0041212000	WASHER, FLAT	2	
32	0805009804	STAY RUBBER	2	
33	0030012000	HEX NUT	2	
34	B4234500804	COVER	1	
35	0016906016	HEX HEAD BOLT	6	

DCA-56SPX—ACTUATOR ASSY.

ENGINE OPERATING PANEL ASSY.

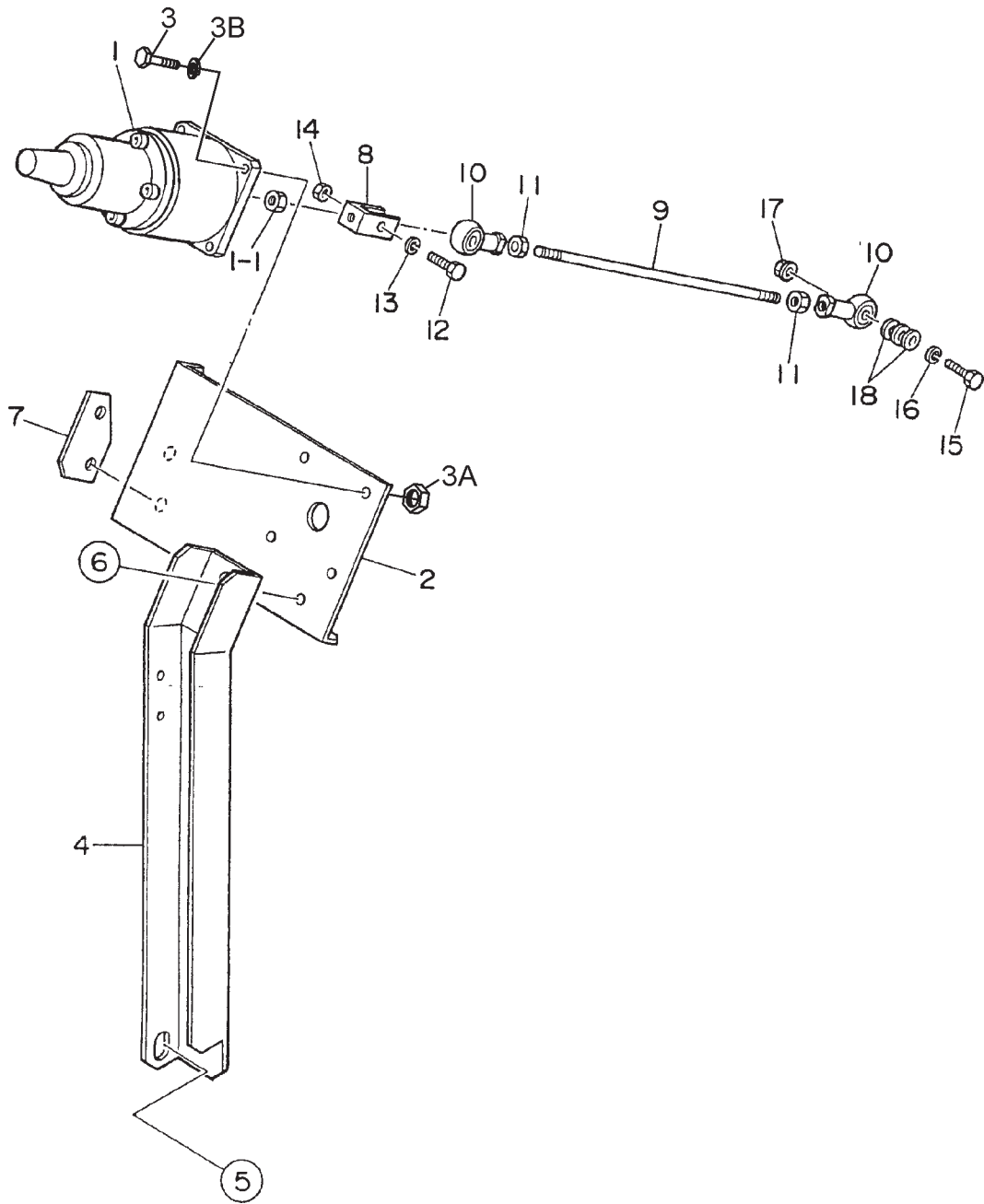

DCA-56SPX— ACTUATOR ASSY.

ACTUATOR ASSY.

<u>NO.</u>	<u>PART NO.</u>	<u>PART NAME</u>	<u>QTY.</u>	<u>REMARKS</u>
1	0602150081	ACTUATOR	1	
1-1	0030006000	HEX NUT	1	
2	B5354200104	BRACKET	1	
3	0343502090	HEX SOCKET HEAD CAP SCREW	4	
3A	0036302000	HEX NUT	4	
3B	004302000	WASHER, LOCK	4	
4	B5354600104	BRACKET	1	
5	0017112020	HEX HEAD BOLT	1	
6	0016908020	HEX HEAD BOLT	1	
7	B5354600004	SPACER	1	
8	0602180090	CLEVIS	1	
9	B5354300004	THROTTLE THREAD	1	
10	0602180290	ROD END	2	
11	0036302000	HEX NUT	2	
12	0343002010	HEX HEAD BOLT	1	
13	0043002000	WASHER, LOCK	1	
14	0036202000	HEX NUT	1	
15	0010105030	HEX HEAD BOLT	1	
16	0040005000	WASHER, LOCK	1	
17	0207005000	HEX NUT	1	
18	0041205000	WASHER, FLAT	3	

DCA-56SPX— BATTERY ASSY.

BATTERY ASSY.

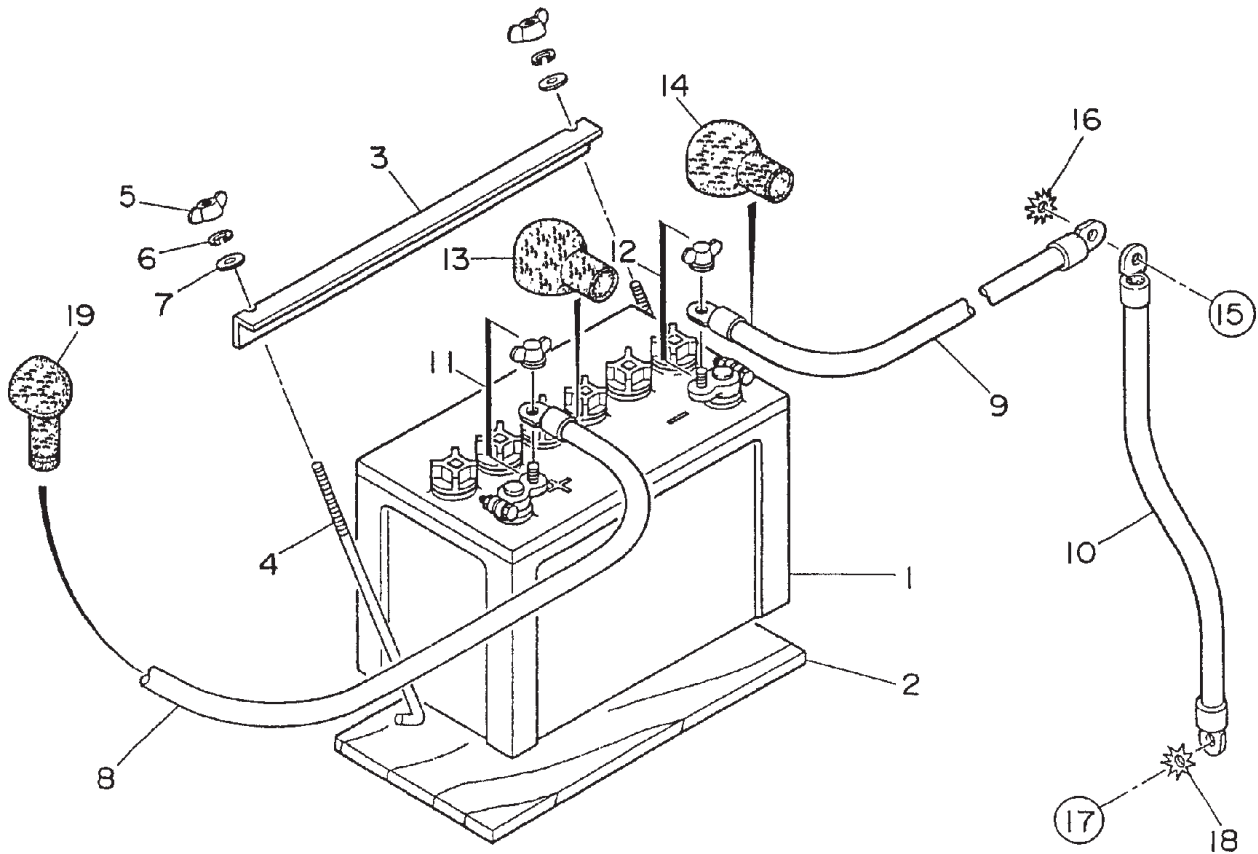

BATTERY ASSY.

<u>NO.</u>	<u>PART NO.</u>	<u>PART NAME</u>	<u>QTY.</u>	<u>REMARKS</u>
1	0168309531	BATTERY	1	
2	B9310500004	BATTERY SHEET	1	
3	B9104000004	BATTERY BAND	1	
4	0805002904	BATTERY BOLT	2	
5	0037808000	WING NUT	2	
6	0040008000	WASHER, LOCK	2	
7	0041608000	WASHER, FLAT	2	
8	B3348400004	BATTERY CABLE	1	
9	B5346400504	BATTERY CABLE	1	
10	B3347200404	BATTERY CABLE	1	
11	0602220310	TERMINAL ASSY	1	
12	0602220311	TERMINAL ASSY	1	
13	0845040414	TERMINAL CAP	1	
14	0845041304	TERMINAL CAP	1	
15	0017112025	HEX HEAD BOLT	1	
16	0040512000	TOOTHED WASHER	1	
17	0017110020	HEX HEAD BOLT	1	
18	0040510000	TOOTHED WASHER	1	
19	0602220622	TERMINAL CAP	1	

DCA-56SPX— MUFFLER ASSY.

MUFFLER ASSY.

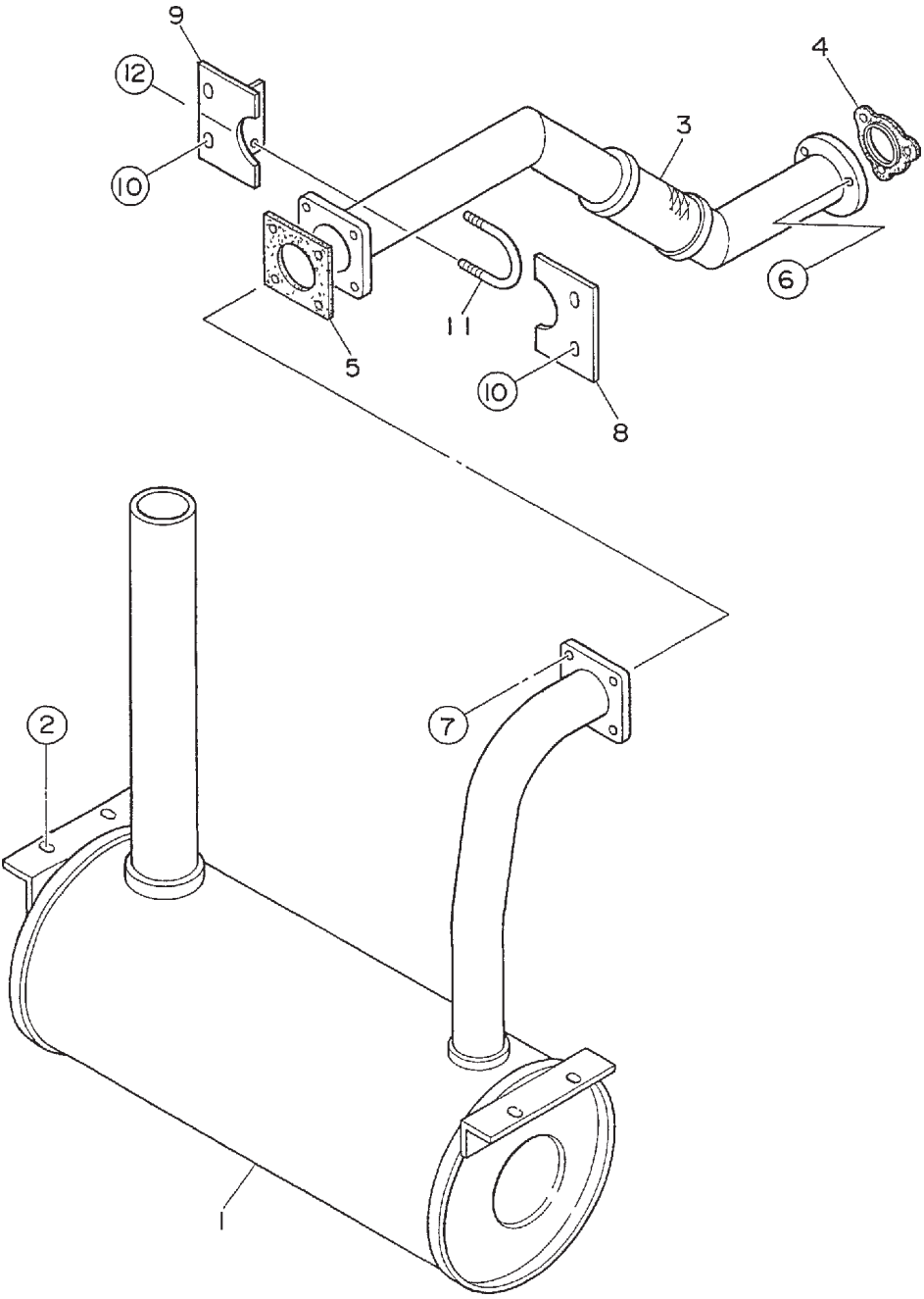

DCA-56SPX— MUFFLER ASSY.

MUFFLER ASSY.

<u>NO.</u>	<u>PART NO.</u>	<u>PART NAME</u>	<u>QTY.</u>	<u>REMARKS</u>
1	B5330100303	MUFFLER	1	
2	0016910025	HEX HEAD BOLT	4	
3	B5333000203	EXHAUST PIPE	1	
4	0602320101	GASKET	1	ISUZU 894369-0210
5	B5333200004	GASKET	1	
6	0039308000	HEX NUT	6	
7	0016908040	HEX HEAD BOLT	4	
8	8102354004	EXHAUST PIPE COVER	1	
9	B5332300004	EXHAUST PIPE COVER	1	
10	0016908020	HEX HEAD BOLT	4	
11	0603320116	U BOLT	1	
12	0030008000	HEX NUT	4	

DCA-56SPX— FUEL TANK ASSY.

FUEL TANK ASSY.

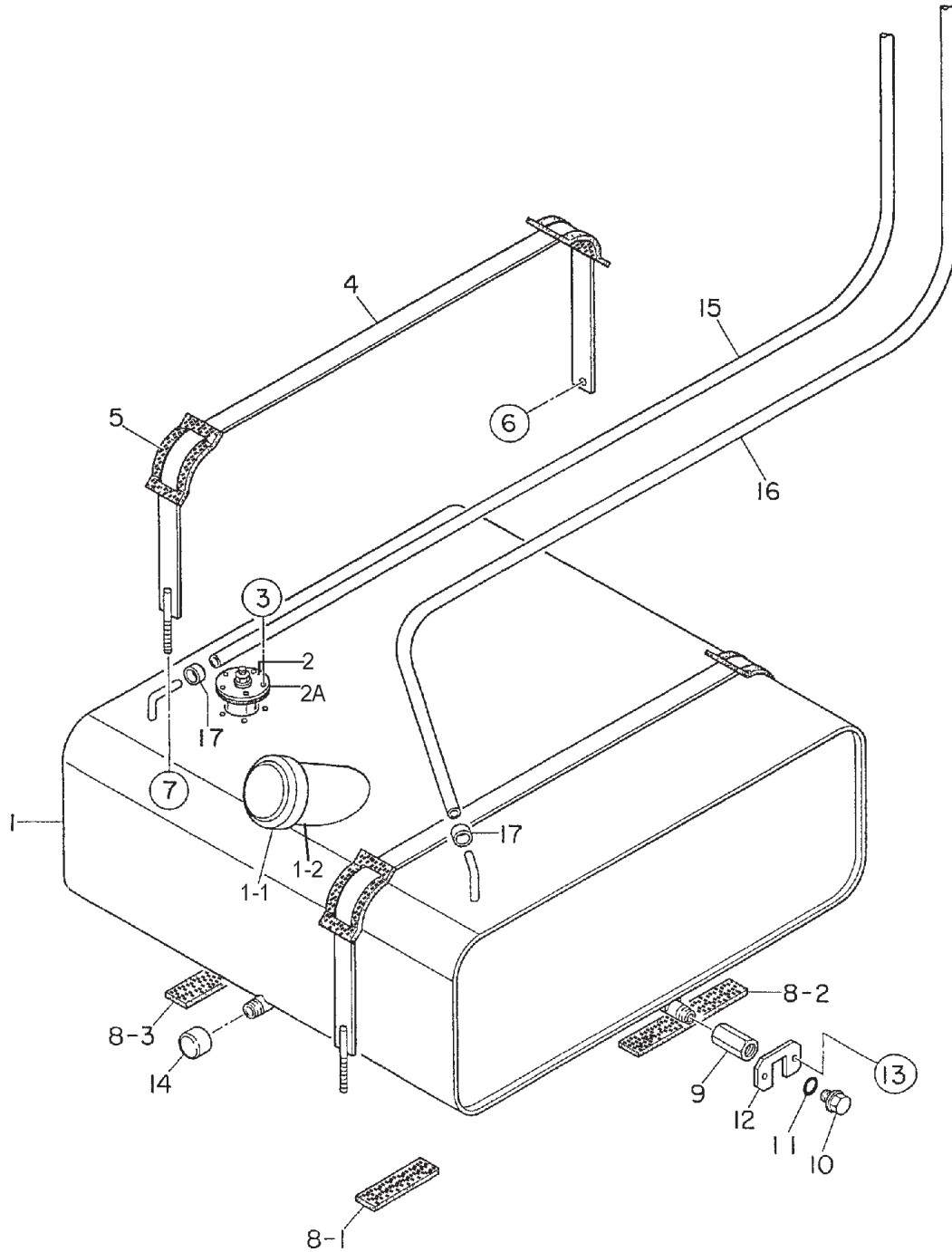

FUEL TANK ASSY.

<u>NO.</u>	<u>PART NO.</u>	<u>PART NAME</u>	<u>QTY.</u>	<u>REMARKS</u>
1	D5363000803	FUEL TANK	1	
1-1	0845500104	FUEL TANK CAP	1	
1-2	0810105400	FUEL TANK	1	
2	0605501074	FUEL GAUGE SENDER	1	
2A	0605516090	GASKET	1	
3	0022905015	MACHINE SCREW	5	
4	B5363200104	TANK BAND	2	
5	0805003414	TANK BAND PAD	4	
6	0016908020	HEX HEAD BOLT	2	
7	0207308000	HEX NUT	2	
8-1	0222100120	TANK SHEET	1	
8-2	0222100200	TANK SHEET	1	
8-3	0222100690	TANK SHEET	1	
9	0845047504	DRAIN JOINT	1	
10	0802011104	PLUG	1	
11	0150000018	O RING	1	
12	B3367700304	LOCK PLATE	1	
13	0019208020	HEX HEAD BOLT	2	
14	0131906000	CAP	1	
15	0191301400	SUCTION HOSE	1	
16	0191301550	RETURN HOSE	1	
17	0605515109	HOSE BAND	4	

DCA-56SPX— ENCLOSURE ASSY.

ENCLOSURE ASSY.

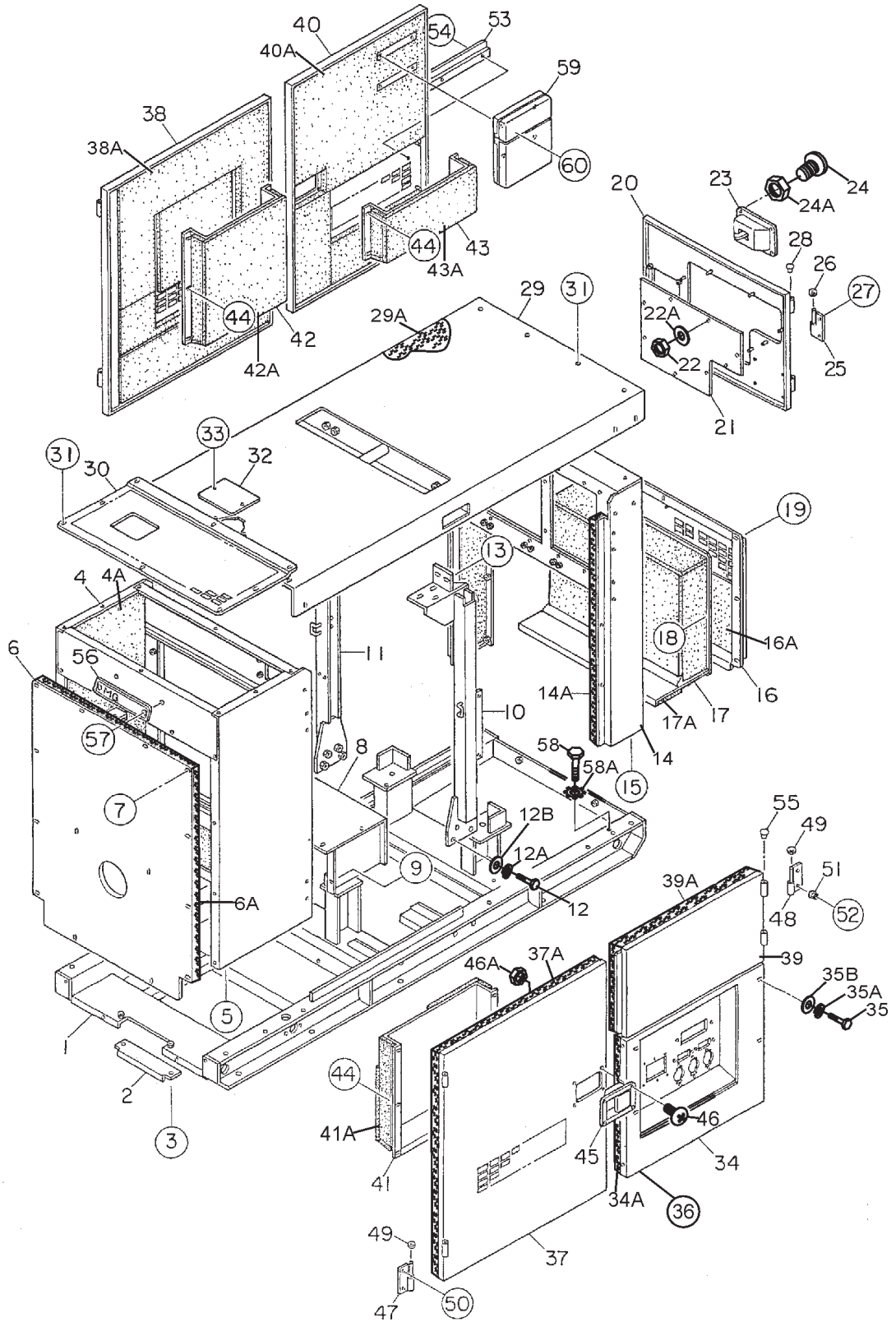

DCA-56SPX— ENCLOSURE ASSY.

ENCLOSURE ASSY.

<u>NO.</u>	<u>PART NO.</u>	<u>PART NAME</u>	<u>QTY.</u>	<u>REMARKS</u>
1	B5413001602	BASE	1	
2	B5413400004	UNDER COVER	1	
3	0016908020	HEX HEAD BOLT	2	
4	B5423000402	FRONT FRAME	1	
4A	B5493100303	ACOUSTIC SHEET	1	
5	0016908020	HEX HEAD BOLT	6	
6	B5423200904	FRONT FRAME COVER	1	
6A	B5493100404	ACOUSTIC SHEET	1	
7	0019208020	HEX HEAD BOLT	14	
8	B5423201103	FRONT FRAME INNER COVER	1	
9	0016908020	HEX HEAD BOLT	7	
10	B5433300203	HANGER	1	
11	B5433300303	HANGER	1	
12	0010114035	HEX HEAD BOLT	8	
12A	0040014000	WASHER, LOCK	8	
12B	0041214000	WASHER, FLAT	8	
13	0017112030	HEX HEAD BOLT	10	
14	B5443000302	REAR FRAME	1	
14A	B5493300104	ACOUSTIC SHEET	1	
15	0016908020	HEX HEAD BOLT	4	
16	B4444302203	REAR COVER	1	
16A	B5493300204	ACOUSTIC SHEET	1	
17	B4444302303	REAR COVER DUCT	1	
17A	B4494302004	LINING	1	
18	0207006000	HEX NUT	12	
19	0019208020	HEX HEAD BOLT	9	
20	B5443200403	REAR DOOR	1	
21	B5443600004	WINDOW PLATE	1	
22	0037906000	HEX NUT	8	
22A	0041206000	WASHER, FLAT	8	
23	B9114000002	DOOR HENDLE ASSY.	1	
24	0021806016	MACHINE SCREW	4	
24A	0030006000	HEX NUT	4	
25	0845047104	HINGE	2	
26	0845045004	WASHER	2	
27	0019208020	HEX HEAD BOLT	3	
28	0845031504	BLIND PLUG	2	
29	B5463000402	ROOF PANEL	1	
29A	B5493500103	ACOUSTIC SHEET	1	
30	B5423201004	FRONT FRAME OVER COVER	1	
31	0019208020	HEX HEAD BOLT	18	
32	8452023004	COVER	1	
33	0019208020	HEX HEAD BOLT	2	

DCA-56SPX—ENCLOSURE ASSY.(CONT.)

ENCLOSURE ASSY.(CONT.)

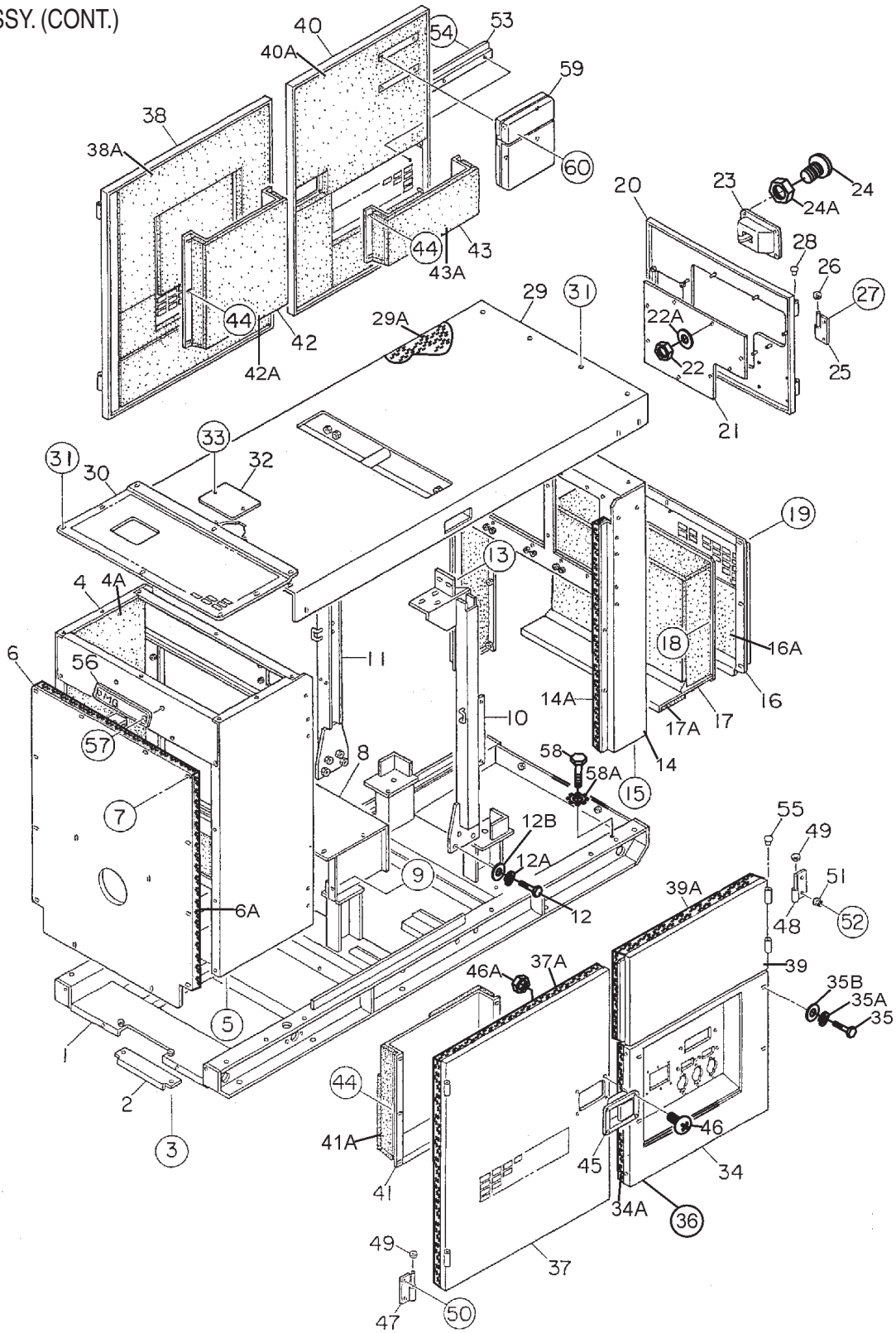

DCA-56SPX— ENCLOSURE ASSY. (CONT.)

ENCLOSURE ASSY. (CONT.)

<u>NO.</u>	<u>PART NO.</u>	<u>PART NAME</u>	<u>QTY.</u>	<u>REMARKS</u>
34	B4454206602	SPLASHER PANEL	1	
34A	B5493401704	ACOUSTIC SHEET	1	
35	0019108055	HEX HEAD BOLT	4	
35A	0042308000	WASHER, LOCK	4	
35B	0042408000	WASHER, FLAT	4	
36	0017108020	HEX HEAD BOLT	2	
37	B5453001103	SIDE DOOR	1	
37B	B5493401004	ACOUSTIC SHEET	1	
38	B5453001203	SIDE DOOR	1	
38B	B5493401204	ACOUSTIC SHEET	1	
39	B5453001303	SIDE DOOR	1	
39B	B5493401404	ACOUSTIC SHEET	1	
40	B5453001403	SIDE DOOR	1	
40B	B5493401504	ACOUSTIC SHEET	1	
41	B5453300704	DUCT	1	
41B	B5493401104	ACOUSTIC SHEET	1	
42	B5453300804	DUCT	1	
42B	B5493401304	ACOUSTIC SHEET	1	
43	B5453300904	DUCT	1	
43B	B5493401604	ACOUSTIC SHEET	1	
44	0207006000	HEX NUT	19	
45	B9114000002	DOOR HANDLE ASSY.	3	
46	0021806015	MACHINE SCREW	12	
46B	0030006000	HEX NUT	12	
47	0845047104	HINGE	4	
48	0845047204	HINGE	4	
49	0845045004	WASHER	8	
50	0019208020	HEX HEAD BOLT	9	
51	0601850097	DOOR STOPPER	8	
52	0025408025	MACHINE SCREW	8	
53	B5453600004	DOOR BRACKET	1	
54	0019206016	HEX HEAD BOLT	3	
55	0845031504	BLIND PLUG	8	
56	0600500090	EMBLEM	1	
57	0021106015	MACHINE SCREW	2	
58	0016908020	HEX HEAD BOLT	1	
58B	0040506000	TOOTHED WASHER	1	

DCA-56SPX— RUBBER SEALS ASSY.

RUBBER SEALS ASSY.

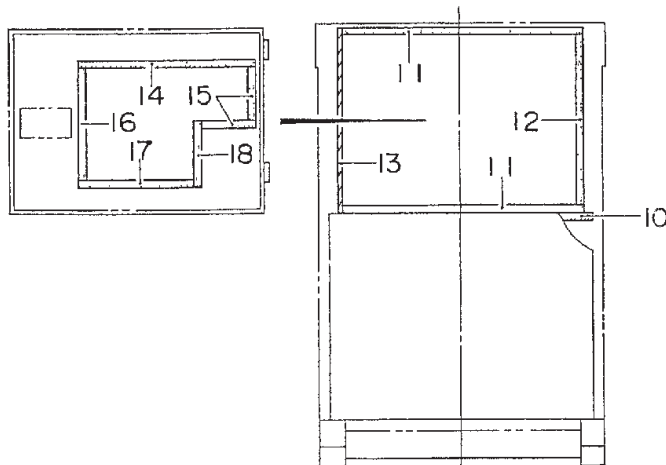
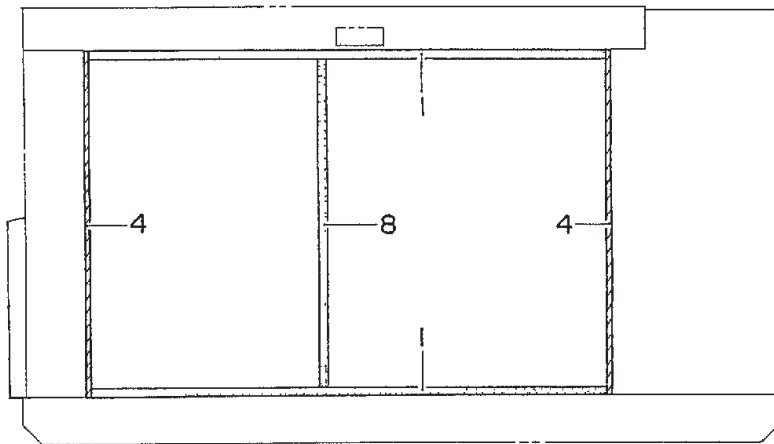
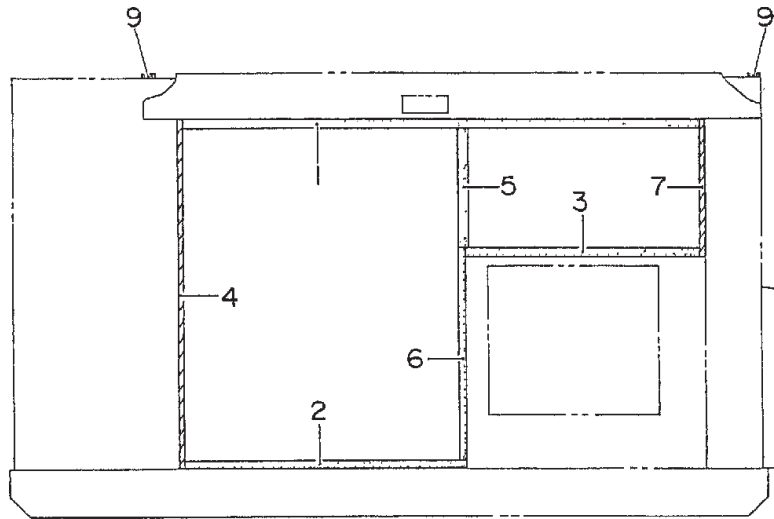

DCA-56SPX— RUBBER SEALS ASSY.

RUBBER SEALS ASSY.

<u>NO.</u>	<u>PART NO.</u>	<u>PART NAME</u>	<u>QTY.</u>	<u>REMARKS</u>
1	0228901660	SEAL RUBBER	3	
2	0228900915	SEAL RUBBER	1	
3	0228900745	SEAL RUBBER	1	
4	0228901120	SEAL RUBBER	3	
5	B1491300004	SEAL RUBBER	1	
6	0228800680	SEAL RUBBER	1	
7	0228900440	SEAL RUBBER	1	
8	0228901060	SEAL RUBBER	1	
9	0229200900	SEAL RUBBER	2	
10	0229200840	SEAL RUBBER	1	
11	0228800770	SEAL RUBBER	2	
12	0228800540	SEAL RUBBER	1	
13	0228800580	SEAL RUBBER	1	
14	0228100550	SEAL RUBBER	1	
15	0228100170	SEAL RUBBER	2	
16	0228100350	SEAL RUBBER	1	
17	0228100360	SEAL RUBBER	1	
18	0228100180	SEAL RUBBER	1	

DCA-56SPX— NAMEPLATE AND DECALS ASSY.

NAMEPLATE AND DECALS ASSY.

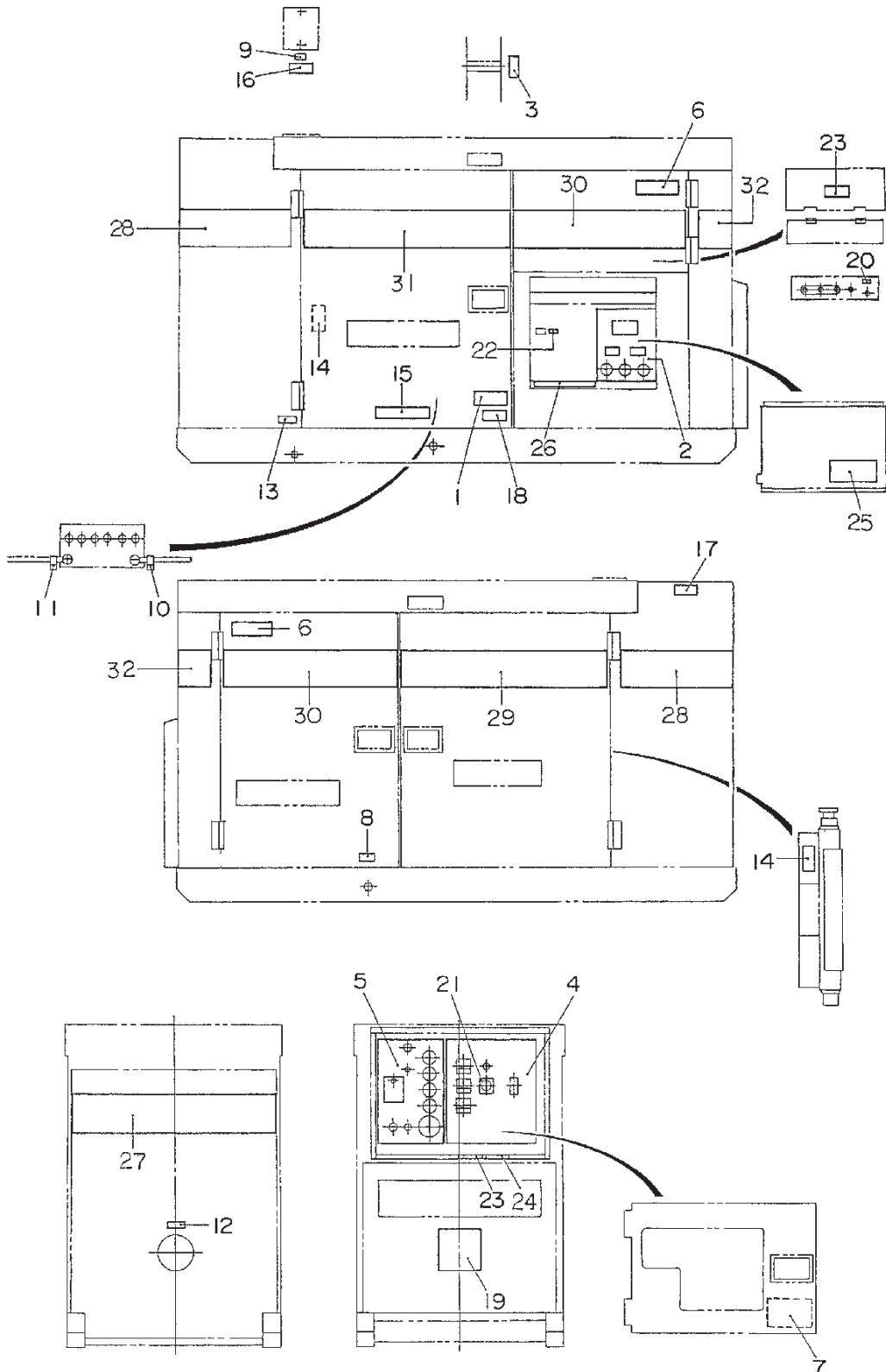

DCA-56SPX— NAMEPLATE AND DECALS ASSY.

NAME PLATE AND DECALS ASSY.

<u>NO.</u>	<u>PART NO.</u>	<u>PART NAME</u>	<u>QTY.</u>	<u>REMARKS</u>
1	C9505300004	DECAL : CAUTION	1	C90530000
2	M1550002203	DECAL : AUXILLARY OUTPUT	1	M15000220
3	M1550001304	DECAL : LIFTING CAP	1	M15000130
4	B4551007003	DECAL : GENERATOR CONTROL	1	B45100700
5	B5550000103	DECAL : ENGINE OPERATING	1	B55000010
6	C9522100003	DECAL : CAUTION	2	C92210000
7	B4551007103	DECAL : OPERATING PRODEDURES	1	B45100710
8	6360620204	DECAL : OIL DRAIN PLUG	1	S-1885
9	6360610304	DECAL : WATER	1	S-1880
10	0800669504	DECAL : -	1	S-2091
11	0800689404	DECAL : +	1	S-2090
12	1320620904	DECAL : DIESEL FUEL	1	S-1756
13	6360620004	DECAL : FUEL DRAIN PLUG	1	S-1883
14	B9504000404	DECAL : WARNING	2	B90400040
15	1320610603	DECAL : WATER * OIL CHECK	1	S-1760
16	B9504100104	DECAL : WARNING	1	B90410010
17	B9504200004	DECAL : WARNING	1	B90420000
18	B9504000304	DECAL : CAUTION	1	B90400030
19	0840625902	DECAL : MQ	1	S-3057
20	0840614104	DECAL : GROUND	1	S-2635
21	0840505604	DECAL : AMMETER CHARGE- OVER SWITCH	1	N-4590
22	9039209064	DECAL : START CONTACT	1	S-4468
23	B9531100604	DECAL : WARNING	2	B93110060
24	B9521100404	DECAL : SAFETY INSTRUCTIONS	1	B92110040
25	M9520100404	DECAL : DANGER	1	M92010040
26	M9520100503	DECAL : WARNING	1	M92010050
27	B5560100003	STRIPE : WHISPERWATT	1	
28	B5560100104	STRIPE : MQ POWER	2	
29	B5560100303	STRIPE	1	
30	B5560100403	STRIPE	2	
31	B5560100203	STRIPE	1	
32	B4561101104	STRIPE : 56	2	

PAYMENT TERMS

Terms of payment for parts are net 30 days.

FREIGHT POLICY

All parts orders will be shipped collect or prepaid with the charges added to the invoice. All shipments are F.O.B. point of origin. Multiquip's responsibility ceases when a signed manifest has been obtained from the carrier, and any claim for shortage or damage must be settled between the consignee and the carrier.

MINIMUM ORDER

The minimum charge for orders from Multiquip is \$15.00 net. Customers will be asked for instructions regarding handling of orders not meeting this requirement.

RETURNED GOODS POLICY

Return shipments will be accepted and credit will be allowed, subject to the following provisions:

1. A Returned Material Authorization must be approved by Multiquip prior to shipment.
2. To obtain a Return Material Authorization, a list must be provided to Multiquip Parts Sales that defines item numbers, quantities, and descriptions of the items to be returned.
 - a. The parts numbers and descriptions must match the current parts price list.
 - b. The list must be typed or computer generated.
 - c. The list must state the reason(s) for the return.
 - d. The list must reference the sales order(s) or invoice(s) under which the items were originally purchased.
 - e. The list must include the name and phone number of the person requesting the RMA.
3. A copy of the Return Material Authorization must accompany the return shipment.
4. Freight is at the sender's expense. All parts must be returned freight prepaid to Multiquip's designated receiving point.

5. Parts must be in new and resalable condition, in the original Multiquip package (if any), and with Multiquip part numbers clearly marked.
6. The following items are not returnable:
 - a. Obsolete parts. (If an item is in the price book and shows as being replaced by another item, it is obsolete.)
 - b. Any parts with a limited shelf life (such as gaskets, seals, "O" rings, and other rubber parts) that were purchased more than six months prior to the return date.
 - c. Any line item with an extended dealer net price of less than \$5.00.
 - d. Special order items.
 - e. Electrical components.
 - f. Paint, chemicals, and lubricants.
 - g. Decals and paper products.
 - h. Items purchased in kits.
7. The sender will be notified of any material received that is not acceptable.
8. Such material will be held for five working days from notification, pending instructions. If a reply is not received within five days, the material will be returned to the sender at his expense.
9. Credit on returned parts will be issued at dealer net price at time of the original purchase, less a 15% restocking charge.
10. In cases where an item is accepted, for which the original purchase document can not be determined, the price will be based on the list price that was effective twelve months prior to the RMA date.
11. Credit issued will be applied to future purchases only.

PRICING AND REBATES

Prices are subject to change without prior notice. Price changes are effective on a specific date and all orders received on or after that date will be billed at the revised price. Rebates for price declines and added charges for price increases will not be made for stock on hand at the time of any price change.

Multiquip reserves the right to quote and sell direct to Government agencies, and to Original Equipment Manufacturer accounts who use our products as integral parts of their own products.

SPECIAL EXPEDITING SERVICE

A \$35.00 surcharge will be added to the invoice for special handling including bus shipments, insured parcel post or in cases where Multiquip must personally deliver the parts to the carrier.

LIMITATIONS OF SELLER'S LIABILITY

Multiquip shall not be liable hereunder for damages in excess of the purchase price of the item with respect to which damages are claimed, and in no event shall Multiquip be liable for loss of profit or good will or for any other special, consequential or incidental damages.

LIMITATION OF WARRANTIES

No warranties, express or implied, are made in connection with the sale of parts or trade accessories nor as to any engine not manufactured by Multiquip. Such warranties made in connection with the sale of new, complete units are made exclusively by a statement of warranty packaged with such units, and Multiquip neither assumes nor authorizes any person to assume for it any other obligation or liability whatever in connection with the sale of its products. Apart from such written statement of warranty, there are no warranties, express, implied or statutory, which extend beyond the description of the products on the face hereof.

Effective: February 22, 2006

OPERATION AND PARTS MANUAL

HERE'S HOW TO GET HELP

PLEASE HAVE THE MODEL AND SERIAL
NUMBER ON-HAND WHEN CALLING

MULTIQUIP CORPORATE OFFICE

18910 Wilmington Ave Tel. (800) 421-1244
Carson, CA 90746 Fax (800) 537-3927
Contact: mq@multiquip.com
Web: www.multiquip.com

MQ Power

1800 Water Ridge Rd. Tel. (800) 883-2551
Suite 500/600 Fax (972) 315-1847
Lewisville, TX 75057
Contact: mqpower@multiquip.com
Web: www.mqpower.com

MQ Parts Department

800-427-1244 Fax: 800-672-7877
310-537-3700 Fax: 310-637-3284

Service/Tech Support/Warranty

800-835-2551 Fax: 310-638-8046

© COPYRIGHT 2010, MULTIQUIP INC.

MQ Power and the MQ Power logo are registered trademarks of Multiquip Inc. and may not be used, reproduced, or altered without written permission. All other trademarks are the property of their respective owners and used with permission.

This manual MUST accompany the equipment at all times. This manual is considered a permanent part of the equipment and should remain with the unit if resold.

The information and specifications included in this publication were in effect at the time of approval for printing. Illustrations, descriptions, references and technical data contained in this manual are for guidance only and may not be considered as binding. Multiquip Inc. reserves the right to discontinue or change specifications, design or the information published in this publication at any time without notice and without incurring any obligations.

Further, MQ Power disclaims any warranties or guaranties, expressed or implied, with regards to the information contained in this manual.

Your Local Dealer is:

Manufactured for
Multiquip Inc.
by
DENYO CO., LTD, JAPAN[®]

